



Agilent 1200 Series Standard and Preparative Autosamplers



User Manual



Agilent Technologies

Notices

© Agilent Technologies, Inc. 2006,2008

No part of this manual may be reproduced in any form or by any means (including electronic storage and retrieval or translation into a foreign language) without prior agreement and written consent from Agilent Technologies, Inc. as governed by United States and international copyright laws.

Manual Part Number

G1329-90012

Edition

11/08

Printed in Germany

Agilent Technologies
Hewlett-Packard-Strasse 8
76337 Waldbronn

Research Use Only

Not for use in Diagnostic Procedures.

Warranty

The material contained in this document is provided “as is,” and is subject to being changed, without notice, in future editions. Further, to the maximum extent permitted by applicable law, Agilent disclaims all warranties, either express or implied, with regard to this manual and any information contained herein, including but not limited to the implied warranties of merchantability and fitness for a particular purpose. Agilent shall not be liable for errors or for incidental or consequential damages in connection with the furnishing, use, or performance of this document or of any information contained herein. Should Agilent and the user have a separate written agreement with warranty terms covering the material in this document that conflict with these terms, the warranty terms in the separate agreement shall control.

Technology Licenses

The hardware and/or software described in this document are furnished under a license and may be used or copied only in accordance with the terms of such license.

Restricted Rights Legend

If software is for use in the performance of a U.S. Government prime contract or subcontract, Software is delivered and licensed as “Commercial computer software” as defined in DFAR 252.227-7014 (June 1995), or as a “commercial item” as defined in FAR 2.101(a) or as “Restricted computer software” as defined in FAR 52.227-19 (June 1987) or any equivalent agency regulation or contract clause. Use, duplication or disclosure of Software is subject to Agilent Technologies’ standard commercial license terms, and non-DOD Departments and Agencies of the U.S. Government will

receive no greater than Restricted Rights as defined in FAR 52.227-19(c)(1-2) (June 1987). U.S. Government users will receive no greater than Limited Rights as defined in FAR 52.227-14 (June 1987) or DFAR 252.227-7015 (b)(2) (November 1995), as applicable in any technical data.

Safety Notices

CAUTION

A **CAUTION** notice denotes a hazard. It calls attention to an operating procedure, practice, or the like that, if not correctly performed or adhered to, could result in damage to the product or loss of important data. Do not proceed beyond a **CAUTION** notice until the indicated conditions are fully understood and met.

WARNING

A **WARNING** notice denotes a hazard. It calls attention to an operating procedure, practice, or the like that, if not correctly performed or adhered to, could result in personal injury or death. Do not proceed beyond a **WARNING** notice until the indicated conditions are fully understood and met.

Contents

1	Introduction to the Autosampler	7
	Introduction to the Autosampler	8
	Sampling Sequence	10
	Sampling Unit	13
	Transport Assembly	16
	Early Maintenance Feedback (EMF)	18
	Electrical Connections	19
	Agilent 1200 Series Interfaces	21
2	Site Requirements and Specifications	23
	Site Requirements	24
	Physical Specifications	27
	Performance Specifications	28
3	Installing the Autosampler	33
	Unpacking the Autosampler	34
	Optimizing the Stack Configuration	37
	Installing the Autosampler	41
	Installing the Thermostatted Autosampler	44
	Flow Connections	48
	Installing the Sample Tray	50
	Transporting the Autosampler	51
4	Using the Autosampler	53
	Solvent Information	54
	Sample Trays	56
	Choice of Vials and Caps	58
5	Optimizing Performance	61
	Optimization for Lowest Carry-over	62
	Fast Injection Cycle and Low Delay Volume	66
	Precise Injection Volume	68

Choice of Rotor Seal	70
6 Troubleshooting and Diagnostics	71
Agilent Lab Monitor & Diagnostic Software	72
Overview of the Sampler's Indicators and Test Functions	73
7 Maintenance	75
Introduction into Maintenance and Repair	76
Overview of Main Repair Procedures	80
Early Maintenance Feedback (EMF)	82
Maintenance Functions	84
Simple Repairs	85
8 Parts and Materials for Maintenance	105
Main Assemblies	106
Analytical-Head Assembly	108
Vial Trays	111
Standard Autosampler Accessory Kit G1329-68725	112
Preparative Autosampler Accessory Kit G2260-68705	113
Maintenance Kit G1313-68730 for G1329A	114
Maintenance Kit G1313-68719 for G1329B	115
Multi-Draw Kit G1313-6871	116
900 µl Injection Upgrade Kit G1363A for G1329A	117
External Tray G1313-60004	118
9 Identifying Cables	119
Cable Overview	120
Analog Cables	122
Remote Cables	125
BCD Cables	130
External Contact Cable	132
CAN/LAN Cables	133
Auxiliary Cable	134
RS-232 Cables	135

10 Appendix 137

General Safety Information	138
Lithium Batteries Information	142
Radio Interference	143
Sound Emission	144
Agilent Technologies on Internet	145

Contents



1 Introduction to the Autosampler

Introduction to the Autosampler	8
Sampling Sequence	10
Injection Sequence	11
Sampling Unit	13
Needle-Drive	14
Analytical head / preparative head	14
Injection-Valve	15
Transport Assembly	16
Early Maintenance Feedback (EMF)	18
Electrical Connections	19
Agilent 1200 Series Interfaces	21



Introduction to the Autosampler

Three models of Agilent 1200 Series autosamplers are available; within this introduction they will be referred to as the standard autosampler (G1329A), the standard autosampler SL (G1329B) and the preparative autosampler (G2260A). Unless otherwise stated all information in this section is valid for all models.

The Agilent 1100 Series autosamplers and Agilent 1200 Series autosamplers are designed for use with other modules of the Agilent 1200 Series LC system, with the HP 1050 Series, or with other LC systems if adequate remote control inputs and outputs are available. The autosamplers are controlled from the Agilent 1200 Series control module (G4208 A Instant Pilot) or from the Agilent ChemStation for LC.

Three sample-rack sizes are available for the autosamplers. The standard full-size rack holds 100×1.8 ml vials, while the two half-size racks provide space for 40×1.8 ml vials and 15×6 ml vials respectively. Any two half-size rack trays can be installed in the autosamplers simultaneously. A specially designed sample-rack holding 100×1.8 ml vials is available for use with thermostatted autosamplers. The half-size racks trays are not designed for an optimal heat transfer when they are used with a thermostatted autosampler.

The autosamplers transport mechanism uses an X-Z-Theta movement to optimize vial pick-up and return. Vials are picked up by the gripper arm, and positioned below the sampling unit. The gripper transport mechanism and sampling unit are driven by motors. Movement is monitored by optical sensors and optical encoders to ensure correct operation. The metering device is always flushed after injection to ensure minimum carry-over.

The standard analytical head device provides injection volumes from 0.1 – 100 μ l. Two preparative head devices provide injection volumes from 0.1 – 900 μ l. One head is limited by a system pressure of 200 bars, the other by a system pressure of 400 bars. The G1329B autosampler SL uses an analytical head providing injection volumes from 0.1 – 100 μ l for pressures up to 600 bar as used in rapid resolution systems.

The six-port injection valve unit (only 5 ports are used) is driven by a high-speed hybrid stepper motor. During the sampling sequence, the valve unit bypasses the autosamplers, and directly connects the flow from the pump to

the column. During injection and analysis, the valve unit directs the flow through the autosamplers which ensures that the sample is injected completely into the column, and that any sample residue is removed from the metering unit and needle from before the next sampling sequence begins. Different valves are available for the standard and preparative autosamplers.

Control of the vial temperature in the thermostatted autosampler is achieved using an additional Agilent 1200 Series module; the ALS thermostat. Details of this module are given in the Agilent 1200 Series thermostatted autosampler Supplemental Manual.

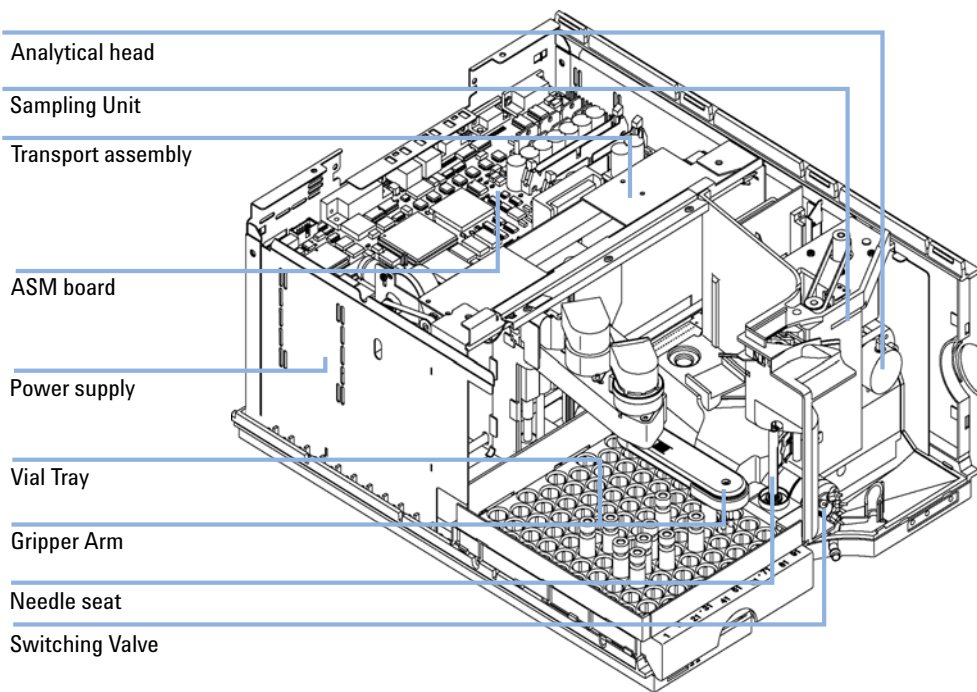

Figure 1 Overview of the Autosampler

Sampling Sequence

The movements of the autosampler components during the sampling sequence are monitored continuously by the autosampler processor. The processor defines specific time windows and mechanical ranges for each movement. If a specific step of the sampling sequence can't be completed successfully, an error message is generated.

Solvent is bypassed from the autosamplers by the injection valve during the sampling sequence. The sample vial is selected by a gripper arm from a static sample rack, or from external vial positions. The gripper arm places the sample vial below the injection needle. The required volume of sample is drawn into the sample loop by the metering device. Sample is applied to the column when the injection valve returns to the mainpass position at the end of the sampling sequence.

The sampling sequence occurs in the following order:

- 1** The injection valve switches to the bypass position.
- 2** The plunger of the metering device moves to the initialization position.
- 3** The gripper arm moves from the home position, and selects the vial. At the same time, the needle lifts out of the seat.
- 4** The gripper arm places the vial below the needle.
- 5** The needle lowers into the vial.
- 6** The metering device draws the defined sample volume.
- 7** The needle lifts out of the vial.
- 8** If the automated needle wash is selected (see [“Using the Automated Needle Wash”](#) on page 63), the gripper arm replaces the sample vial, positions the wash vial below the needle, lowers the needle into the vial, then lifts the needle out of the wash vial.
- 9** The gripper arm checks if the safety flap is in position.
- 10** The gripper arm replaces the vial, and returns to the home position. Simultaneously, the needle lowers into the seat.
- 11** The injection valve switches to the mainpass position.

Injection Sequence

Before the start of the injection sequence, and during an analysis, the injection valve is in the mainpass position (Figure 2 on page 11). In this position, the mobile phase flows through the autosamplers metering device, sample loop, and needle, ensuring all parts in contact with sample are flushed during the run, thus minimizing carry-over.

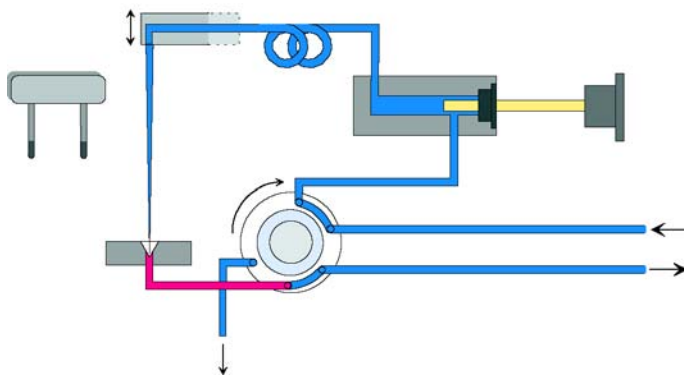

Figure 2 Mainpass Position

When the sample sequence begins, the valve unit switches to the bypass position (Figure 3 on page 11). Solvent from the pump enters the valve unit at port 1, and flows directly to the column through port 6.

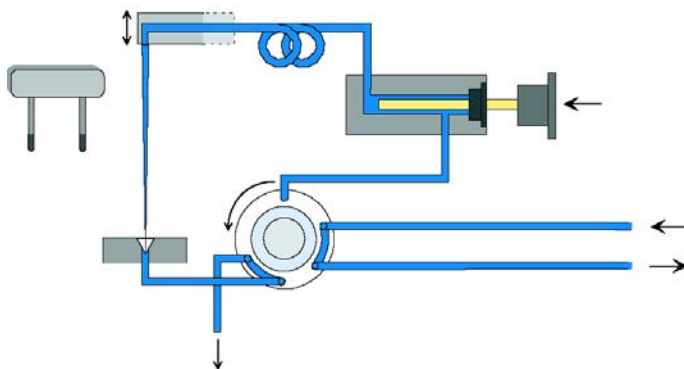

Figure 3 Bypass Position

1 Introduction to the Autosampler

Sampling Sequence

Next, the needle is raised, and the vial is positioned below the needle. The needle moves down into the vial, and the metering unit draws the sample into the sample loop (Figure 4 on page 12).

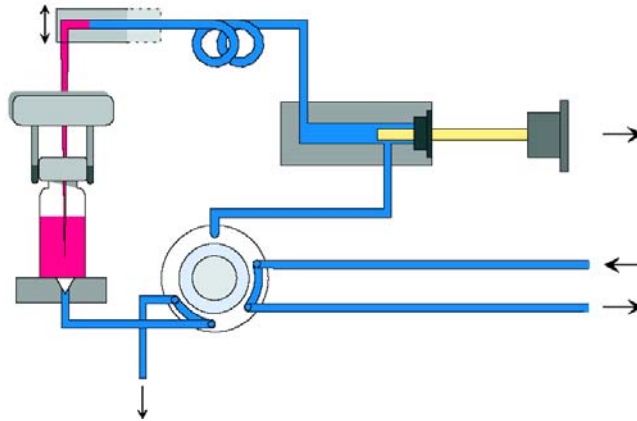

Figure 4 Drawing the Sample

When the metering unit has drawn the required volume of sample into the sample loop, the needle is raised, and the vial is replaced in the sample tray. The needle is lowered into the needle seat, and the injection valve switches back to the mainpass position, flushing the sample onto the column (Figure 5 on page 12).

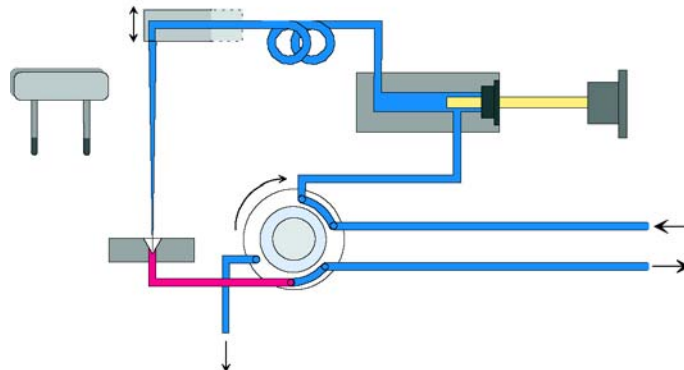

Figure 5 Mainpass Position (Sample Injection)

Sampling Unit

The sampling unit comprises three main assemblies: needle drive, metering device, and injection valve.

NOTE

The replacement sampling unit excludes the injection valve and metering head assemblies.

The sampling units for the standard and the preparative autosamplers are different.

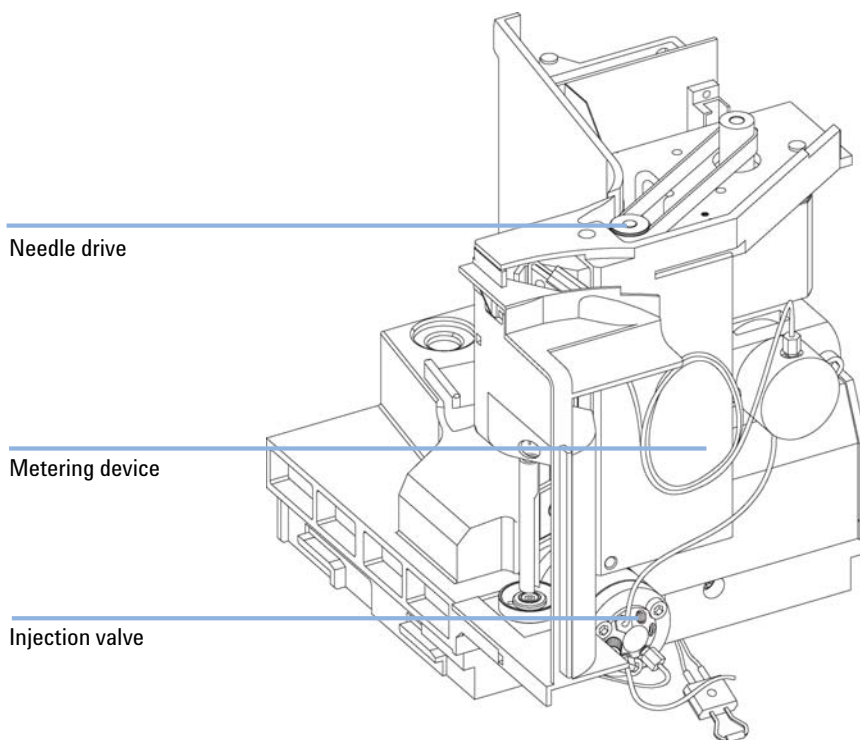

Figure 6 Autosampler Sampling Unit

Needle-Drive

The needle movement is driven by a stepper motor connected to the spindle assembly by a toothed belt. The circular motion of the motor is converted to linear motion by the drive nut on the spindle assembly. The upper and lower needle positions are detected by reflection sensors on the sampling unit flex board, while the needle-in-vial position is determined by counting the motor steps from the upper needle-sensor position.

Analytical head / preparative head

The analytical head is driven by the stepper motor connected to the drive shaft by a toothed belt. The drive nut on the spindle converts the circular movement of the spindle to linear motion. The drive nut pushes the sapphire plunger against the tension of the spring into the analytical head. The base of the plunger sits on the large bearing of the drive nut, which ensures the plunger is always centered. A ceramic ring guides the movement of the plunger in the analytical head. The home position of the plunger is sensed by an infra-red sensor on the sampling unit flex board, while the sample volume is determined by counting the number of steps from the home position. The backward movement of the plunger (driven by the spring) draws sample from the vial.

Table 1 Analytical Head Technical Data

	Standard (100 µl)	Standard (900 µl)	Preparative (900 µl)
Number of steps	15000	15000	15000
Volume resolution	7 nl/motor step	60 nl/motor step	60 nl/motor step
Maximum stroke	100 µl	900 µl	900 µl
Pressure limit	600 bar	200 bar	400 bar
Plunger material	Sapphire	Sapphire	Sapphire

Injection-Valve

The two-position 6-port injection valve is driven by a stepper motor. Only five of the six ports are used (port 3 is not used). A lever/slider mechanism transfers the movement of the stepper motor to the injection valve. Two microswitches monitor switching of the valve (bypass and mainpass end positions).

No valve adjustments are required after replacing internal components.

Table 2 Injection-Valve Technical Data

	Standard	Preparative MBB™	Autosampler SL
Motor type	4 V, 1.2 A stepper motor	4 V, 1.2 A stepper motor	4 V, 1.2 A stepper motor
Seal material	Vespe™ (Tefzel™ available)	PEEK	PEEK
Stator material	Ceramic/PEEK	PEEK	None
Number of ports	6	6	6
Switching time	< 150 ms	< 150 ms	< 150 ms

Transport Assembly

The transport unit comprises an X-axis slide (left-right motion), a Z-axis arm (up-down motion), and a gripper assembly (rotation and vial-gripping).

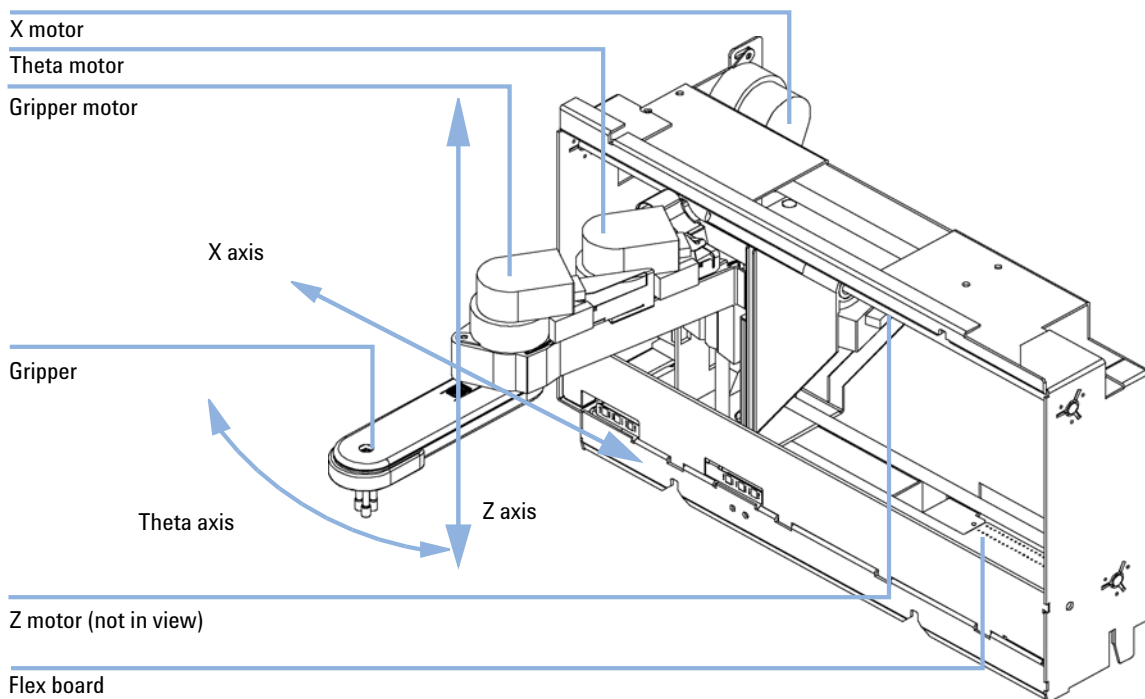

Figure 7 Transport Assembly

The transport assembly uses four stepper motors driven in closed-loop mode for accurate positioning of the gripper assembly for sample-vial transport. The rotational movement of the motors is converted to linear motion (X- and Z-axes) by toothed belts connected to the drive spindles. The rotation (theta axes) of the gripper assembly is transferred from the motor by a toothed belt and series of gears. The opening and closing of the gripper fingers are driven by a stepper motor linked by a toothed belt to the planetary gearing inside the gripper assembly.

The stepper motor positions are determined by the optical encoders mounted onto the stepper-motor housing. The encoders monitor the position of the motors continually, and correct for position errors automatically (e.g. if the gripper is accidentally moved out of position when loading vials into the vial tray). The initialization positions of the moving components are sensed by reflection sensors mounted on the flex board. These positions are used by the processor to calculate the actual motor position. An additional six reflection sensors for tray recognition are mounted on the flex board at the front of the assembly.

Early Maintenance Feedback (EMF)

The early maintenance feedback (EMF) feature monitors the usage of specific components in the instrument, and provides feedback when the user-settable limits have been exceeded. The visual feedback in the user interface provides an indication that maintenance procedures should be scheduled.

For details on EMF counters and how to use them, see [“Early Maintenance Feedback \(EMF\)”](#) on page 82.

Electrical Connections

- The GPIB connector is used to connect the module with a computer. The address and control switch module next to the GPIB connector determines the GPIB address of your module. The switches are preset to a default address and is recognized once after power is switched ON.
- The CAN bus is a serial bus with high speed data transfer. The two connectors for the CAN bus are used for internal Agilent 1200 Series module data transfer and synchronization.
- One analog output provides signals for integrators or data handling systems.
- The interface board slot is used for external contacts and BCD bottle number output or LAN connections.
- The REMOTE connector may be used in combination with other analytical instruments from Agilent Technologies if you want to use features such as start, stop, common shut down, prepare, and so on.
- With the appropriate software, the RS-232C connector may be used to control the module from a computer through a RS-232C connection. This connector is activated and can be configured with the configuration switch. See your software documentation for further information.
- The power input socket accepts a line voltage of 100 – 240 volts AC \pm 10% with a line frequency of 50 or 60 Hz. Maximum power consumption is 300 VA. There is no voltage selector on your module because the power supply has wide-ranging capability. There are no externally accessible fuses, because automatic electronic fuses are implemented in the power supply. The security lever at the power input socket prevents the module cover from being taken off when line power is still connected.

NOTE

Never use cables other than the ones supplied by Agilent Technologies to ensure proper functionality and compliance with safety or EMC regulations.

1 Introduction to the Autosampler

Electrical Connections

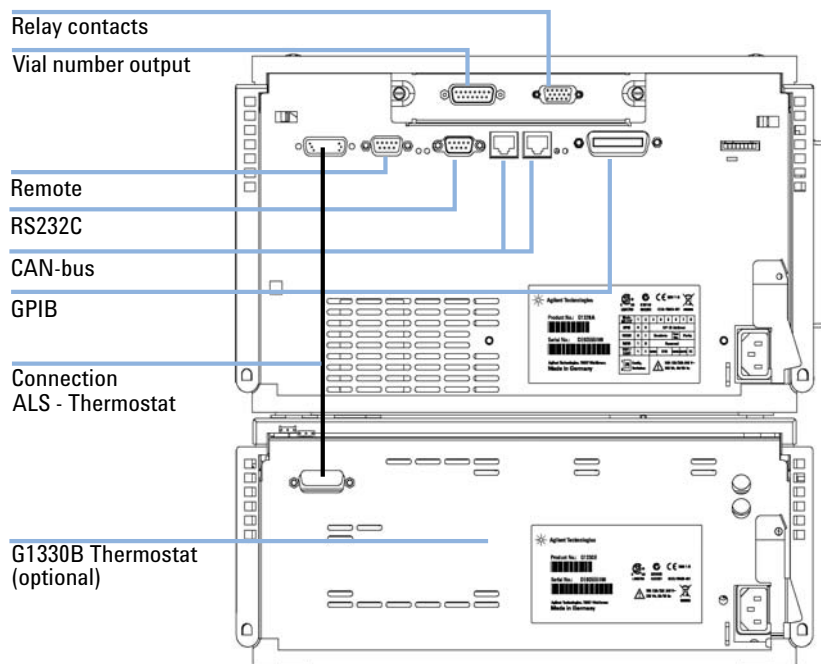

Figure 8 Autosampler (plus Thermostat) Electrical Connections

Agilent 1200 Series Interfaces

The Agilent 1200 Series modules provide the following interfaces:

Table 3 Agilent 1200 Series Interfaces

Interface Type	Pumps	Autosampler	DA Detector MW Detector FL Detector	VW Detector RI Detector	Thermostatted Column Compartment	Vacuum Degasser
CAN	Yes	Yes	Yes	Yes	Yes	No
GPIB	Yes	Yes	Yes	Yes	Yes	No
RS-232C	Yes	Yes	Yes	Yes	Yes	No
APG Remote	Yes	Yes	Yes	Yes	Yes	Yes
Analog	Yes	No	2 ×	1 ×	No	Yes ¹
Interface board ²	Yes	Yes	Yes	Yes	No	No

¹ The vacuum degasser will have a special connector for specific use. For details, see the degasser manual.

² The interface board slot (not common to all modules) provides specific interfacing needs (external contacts, BCD, LAN and so on).

1 Introduction to the Autosampler
Agilent 1200 Series Interfaces



2 Site Requirements and Specifications

Site Requirements	24
Power Consideration	24
Power Cords	25
Bench Space	26
Environment	26
Physical Specifications	27
Performance Specifications	28



Site Requirements

A suitable environment is important to ensure optimum performance of the instrument.

Power Consideration

The autosampler power supply has wide-ranging capability (see [Table 4](#) on page 27). Consequently there is no voltage selector in the rear of the autosampler. There are also no externally accessible fuses, because automatic electronic fuses are implemented in the power supply.

The thermostatted autosampler comprises two modules, the standard or preparative autosampler and the thermostat (G1330B). Both modules have a separate power supply and a power plug for the line connections. The two modules are connected by a control cable and both are turned on by the autosampler module.

WARNING

Damaged electronics

Disconnecting or reconnecting the sampler to thermostat cable when the power cords are connected to either of the two modules will damage the electronics of the modules.

- Make sure the power cords are unplugged before disconnecting or reconnecting the sampler to thermostat cable.

WARNING

Incorrect line voltage at the instrument

Shock hazard or damage of your instrumentation can result, if the devices are connected to a line voltage higher than specified.

- Connect your instrument to the specified line voltage.

CAUTION

Unaccessible power plug.

In case of emergency it must be possible to disconnect the instrument from the power line at any time.

- Make sure the power connector of the instrument can be easily reached and unplugged.
 - Provide sufficient space behind the power socket of the instrument to unplug the cable.
-

Power Cords

Different power cords are offered as options with the module. The female end of all power cords is identical. It plugs into the power-input socket at the rear of the module. The male end of each power cord is different and designed to match the wall socket of a particular country or region.

WARNING

The absence of ground connection and the use of an unspecified power cord can lead to electric shock or short circuit.

Electric Shock

- Never operate your instrumentation from a power outlet that has no ground connection.
 - Never use a power cord other than the Agilent Technologies power cord designed for your region.
-

WARNING

Use of unsupplied cables

Using cables not supplied by Agilent Technologies can lead to damage of the electronic components or personal injury.

- Never use cables other than the ones supplied by Agilent Technologies to ensure proper functionality and compliance with safety or EMC regulations.
-

Bench Space

The autosampler dimensions and weight (see [Table 4](#) on page 27) allow the instrument to be placed on almost any laboratory bench. The instrument requires an additional 2.5 cm (1.0 inch) of space on either side, and approximately 8 cm (3.1 inches) at the rear for the circulation of air, and room for electrical connections. Ensure the autosampler is installed in a horizontal position.

The thermostatted autosampler dimensions and weight allow the instrument to be placed on almost any laboratory bench. The instrument requires an additional 25 cm (10 inches) of space on either side for the circulation of air, and approximately 8 cm (3.1 inches) at the rear for electrical connections. Ensure the autosampler is installed in a level position.

If a complete Agilent 1200 Series system is to be installed on the bench, make sure that the bench is designed to carry the weight of all the modules. For a complete system including the thermostatted autosampler it is recommended to position the modules in two stacks, see [“Optimizing the Stack Configuration”](#) on page 37. Make sure that in this configuration there is 25 cm (10 inches) space on either side of the thermostatted autosampler for the circulation of air.

Environment

Your module will work within specifications at ambient temperatures and relative humidity as described in [Table 4](#) on page 27.

CAUTION

Condensation within the module

Condensation will damage the system electronics.

- Do not store, ship or use your module under conditions where temperature fluctuations could cause condensation within the module.
 - If your module was shipped in cold weather, leave it in its box and allow it to warm slowly to room temperature to avoid condensation.
-

Physical Specifications

Table 4 Physical Specifications

Type	Specification	Comments
Weight	14.2 kg (32 lbs)	
Dimensions (width × depth × height)	200 × 345 × 435 mm (8 × 13.5 × 17 inches)	
Line voltage	100 – 240 VAC, ± 10%	Wide-ranging capability
Line frequency	50 or 60 Hz, ± 5%	
Power consumption	300 VA / 200 W / 683 BTU	Maximum
Ambient operating temperature	0–55 °C (32–131 °F)	See warning "" on page 27
Ambient non-operating temperature	-40–70 °C (-4–158 °F)	
Humidity	< 95%, at 25–40 °C (77–104 °F)	Non-condensing
Operating Altitude	Up to 2000 m (6500 ft)	
Non-operating altitude	Up to 4600 m (14950 ft)	For storing the module
Safety standards: IEC, CSA, UL	Installation Category II, Pollution Degree 2	For indoor use only. Research Use Only. Not for use in Diagnostic Procedures.

WARNING

Hot rear panel

Using the autosampler at high environmental temperatures may cause the rear panel to become hot.

- Do not use the autosampler at environmental temperatures higher than 50 °C (122 °F)

Performance Specifications

Table 5 Performance Specifications Agilent 1200 Series Autosampler (G1329A). Valid when standard 100 µl metering head installed.

Type	Specification
Pressure	Operating range 0 – 40 MPa (0 – 400 bar, 0 – 5900 psi)
GLP features	Early maintenance feedback (EMF), electronic records of maintenance and errors
Communications	Controller-area network (CAN). GPIB (IEEE-448), RS232C, APG-remote standard, optional four external contact closures and BCD vial number output
Safety features	Leak detection and safe leak handling, low voltages in maintenance areas, error detection and display
Injection range	0.1 – 100 µl in 0.1 µl increments Up to 1500 µl with multiple draw (hardware modification required)
Replicate injections	1 – 99 from one vial
Precision	< 0.25% RSD from 5 – 100 µl, < 1% RSD 1 – 5 µl variable volume
Minimum sample volume	1 µl from 5 µl sample in 100 µl microvial, or 1 µl from 10 µl sample in 300 µl microvial
Carryover	Typically < 0.1%, < 0.05% with external needle cleaning
Sample viscosity range	0.2 – 50 cp
Replicate injections per vial	1 – 99
Sample capacity	100 × 2-ml vials in 1 tray 40 × 2-ml vials in ½ tray 15 × 6-ml vials in ½ tray (Agilent vials only)
Injection cycle time	Typically 50 s depending on draw speed and injection volume

Table 6 Performance Specifications Agilent 1200 Series standard autosampler (G1329A). Valid when standard 900 µl metering head installed.

Type	Specification
Pressure	Operating range 0 – 20 MPa (0 – 200 bar, 0 – 2950 psi)
GLP features	Early maintenance feedback (EMF), electronic records of maintenance and errors
Communications	Controller-area network (CAN), GPIB (IEEE-448), RS232C, APG-remote standard, optional four external contact closures and BCD vial number output
Safety features	Leak detection and safe leak handling, low voltages in maintenance areas, error detection and display
Injection range	0.1 – 900 µl in 0.1 µl increments (recommended 1 µl increments) Up to 1800 µl with multiple draw (hardware modification required)
Replicate injections	1 – 99 from one vial
Precision	Typically < 0.5% RSD of peak areas from 5 – 2000 µl, Typically < 1% RSD of peak areas from 2000 – 5000 µl, Typically < 3% RSD of peak areas from 1 – 5 µl
Minimum sample volume	1 µl from 5 µl sample in 100 µl microvial, or 1 µl from 10 µl sample in 300 µl microvial
Carryover	Typically < 0.1%, < 0.05% with external needle cleaning
Sample viscosity range	0.2 – 50 cp
Sample capacity	100 × 2-ml vials in 1 tray 40 × 2-ml vials in ½ tray 15 × 6-ml vials in ½ tray (Agilent vials only)
Injection cycle time	50 s for draw speed 200 µl/min, ejection speed 200 µl/min, injection volume 5 µl

2 Site Requirements and Specifications

Performance Specifications

Table 7 Performance Specifications Agilent 1200 Series standard autosampler SL (G1329B).

Type	Specification
Pressure	Operating range 0 – 60 MPa (0 – 600 bar, 0 – 8850 psi)
GLP features	Early maintenance feedback (EMF), electronic records of maintenance and errors
Communications	Controller-area network (CAN), GPIB (IEEE-448), RS232C, APG-remote standard, optional four external contact closures and BCD vial number output
Safety features	Leak detection and safe leak handling, low voltages in maintenance areas, error detection and display
Injection range	0.1 – 100 µl in 0.1 µl increments (recommended 1 µl increments) Up to 15 00 µl with multiple draw (hardware modification required)
Replicate injections	1 – 99 from one vial
Precision	Typically < 0.25% RSD of peak areas from 5 – 100 µl, Typically < 1% RSD of peak areas from 1 – 5 µl,
Minimum sample volume	1 µl from 5 µl sample in 100 µl microvial, or 1 µl from 10 µl sample in 300 µl microvial
Carryover	Typically < 0.1%, < 0.05% with external needle cleaning
Sample viscosity range	0.2 – 50 cp
Sample capacity	100 × 2-ml vials in 1 tray 40 × 2-ml vials in ½ tray 15 × 6-ml vials in ½ tray (Agilent vials only)
Injection cycle time	50 s for draw speed 200 µl/min, ejection speed 200 µl/min, injection volume 5 µl

Table 8 Performance Specifications Agilent 1200 Series Preparative Autosampler (G2260A)

Type	Specification
Pressure	Operating range 0 – 40 MPa (0 – 400 bar, 0 – 5800psi)
GLP features	Early maintenance feedback (EMF), electronic records of maintenance and errors
Communications	Controller-area network (CAN). GPIB (IEEE-448), RS232C, APG-remote standard, optional four external contact closures and BCD vial number output
Safety features	Leak detection and safe leak handling, low voltages in maintenance areas, error detection and display
Injection range	0.1 – 900 μ l in 0.1 μ l increments (recommended 1 μ l increments) Up to 1800 μ l with multiple draw (hardware modification required) Up to 5000 μ l with multiple draw (hardware modification required)
Replicate injections	1 – 99 from one vial
Precision	Typically < 0.5% RSD of peak areas from 5 – 2000 μ l, Typically < 1% RSD of peak areas from 2000 – 5000 μ l, Typically < 3% RSD of peak areas from 1 – 5 μ l
Minimum sample volume	1 μ l from 5 μ l sample in 100 μ l microvial, or 1 μ l from 10 μ l sample in 300 μ l microvial
Sample viscosity range	0.2 – 50 cp
Sample capacity	100 \times 2-ml vials in 1 tray 15 \times 6-ml vials in 1/2 tray (Agilent vials only)
Injection cycle time	Typically 50 s, depending on draw speed and injection volume

2 Site Requirements and Specifications

Performance Specifications



3 Installing the Autosampler

Unpacking the Autosampler	34
Damaged Packaging	34
Delivery Checklist	34
Optimizing the Stack Configuration	37
Installing the Autosampler	41
Installing the Thermostatted Autosampler	44
Flow Connections	48
Installing the Sample Tray	50
Transporting the Autosampler	51



Unpacking the Autosampler

CAUTION

Mechanical damage of the autosampler

If the transport assembly is not parked, the autosampler could be damaged due to excessive shock of the shipping container during transport.

→ Always park the transport assembly before shipment (see “[Transporting the Autosampler](#)” on page 51).

Damaged Packaging

Upon receipt of your autosampler, inspect the shipping containers for any signs of damage. If the containers or cushioning material are damaged, save them until the contents have been checked for completeness and the autosampler has been checked mechanically and electrically. If the shipping container or cushioning material is damaged, notify the carrier and save the shipping material for the carriers inspection.

Delivery Checklist

Ensure all parts and materials have been delivered with the autosampler. The instrument box contains the instrument and an Accessory kit. A separate box contains the reference manual and the power cable.

In [Table 9](#) on page 35 and [Table 10](#) on page 36 are listed the content of each accessory kit.

Please report missing or damaged parts to your local Agilent Technologies sales and service office.

Table 9 G1329A/G1329B - Standard Autosampler Accessory Kit Contents G1329-68725

Description	Part Number
Tubing assembly	5063-6527
CAN cable, 1 m long	5181-1519
Screw cap vials, clear 100/pk	5182-0714
Blue screw caps 100/pk	5182-0717
Label halftray	5989-3890
Vial instruction sheet	no PN
Wrenches 1/4 - 5/16 inch	8710-0510
Rheotool socket wrench 1/4 inch	8710-2391
Hex key 4 mm, 15 cm long, T-handle	8710-2392
Hex key 9/64 inch, 15 cm long, T- handle	8710-2394
Hex key 2.5 mm, 15 cm long, straight handle	8710-2412
Finger caps (x3) ¹	5063-6506
Front door cooled autosampler	G1329-40301
Air channel adapter	G1329-43200
Cover insulation	no PN
Capillary 0.17 mm, 900 mm	G1329-87300
Capillary heat exchanger	01090-87306
Note for Agilent 1200 Series Autosampler door upgrade	no PN

¹ Reorder gives pack of 15

3 Installing the Autosampler

Unpacking the Autosampler

Table 10 G2260A - Preparative Autosampler Accessory Kit Contents G2260-68705

Description	Part Number
Tubing assembly	5063-6527
Filter promo kit	5064-8240
CAN cable, 1 m long	5181-1519
Screw cap vials, clear 100/pk	5182-0714
Blue screw caps 100/pk	5182-0717
Label halftray	5989-3890
Wrenches 1/4 - 5/16 inch	8710-0510
Rheotool socket wrench 1/4 inch	8710-2391
Hex key 4 mm, 15 cm long, T-handle	8710-2392
Hex key 9/64 inch, 15 cm long, T- handle	8710-2394
Hex key 2.5 mm, 15 cm long, straight handle	8710-2412
Finger caps x3 (reorder gives pack of 15)	5063-6506
Front door cooled autosampler	G1329-40301
Air channel adapter	G1329-43200
Tray for 15 x 6 ml vials (x2)	G1313-44513
Union, loop extension	5022-2133
Seat extension capillary (500 µl)	G1313-87307
Seat extension capillary (1500 µl)	G1313-87308
Sampler - Column capillary	G2260-87300

Optimizing the Stack Configuration

If your autosampler is part of a system, you can ensure optimum performance by installing the autosampler in the stack in the position shown in [Figure 9](#) on page 37 and [Figure 10](#) on page 38. [Figure 11](#) on page 39 and [Figure 12](#) on page 40 show the configuration recommended for a thermostatted autosampler. These configurations optimize the system flow path, ensuring minimum delay volume.

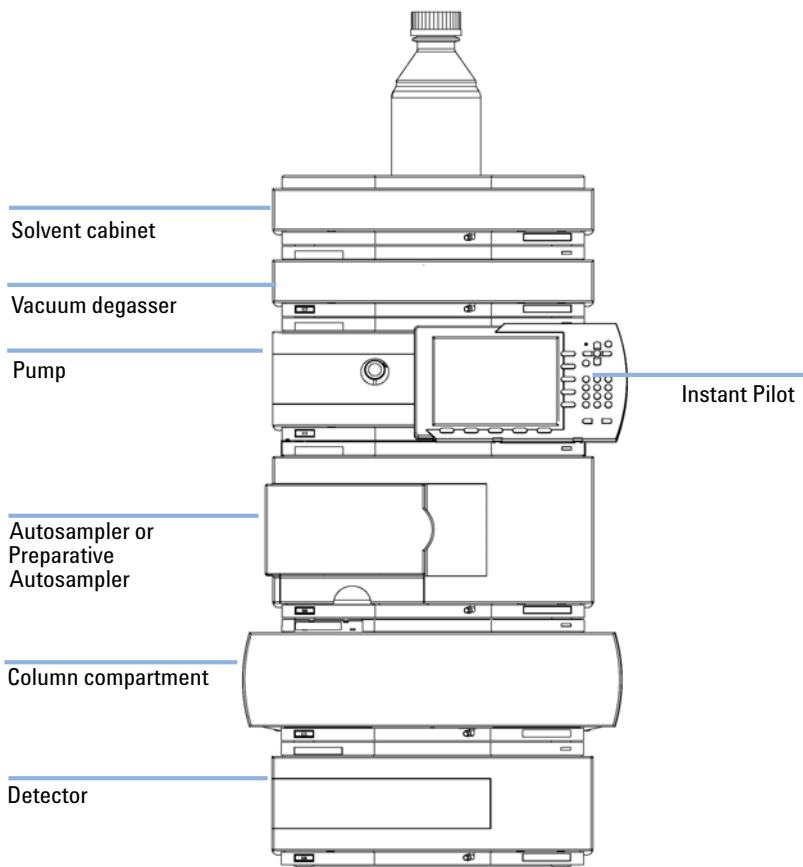

Figure 9 Recommended Stack Configuration for an Autosampler (Front View)

3 Installing the Autosampler

Optimizing the Stack Configuration

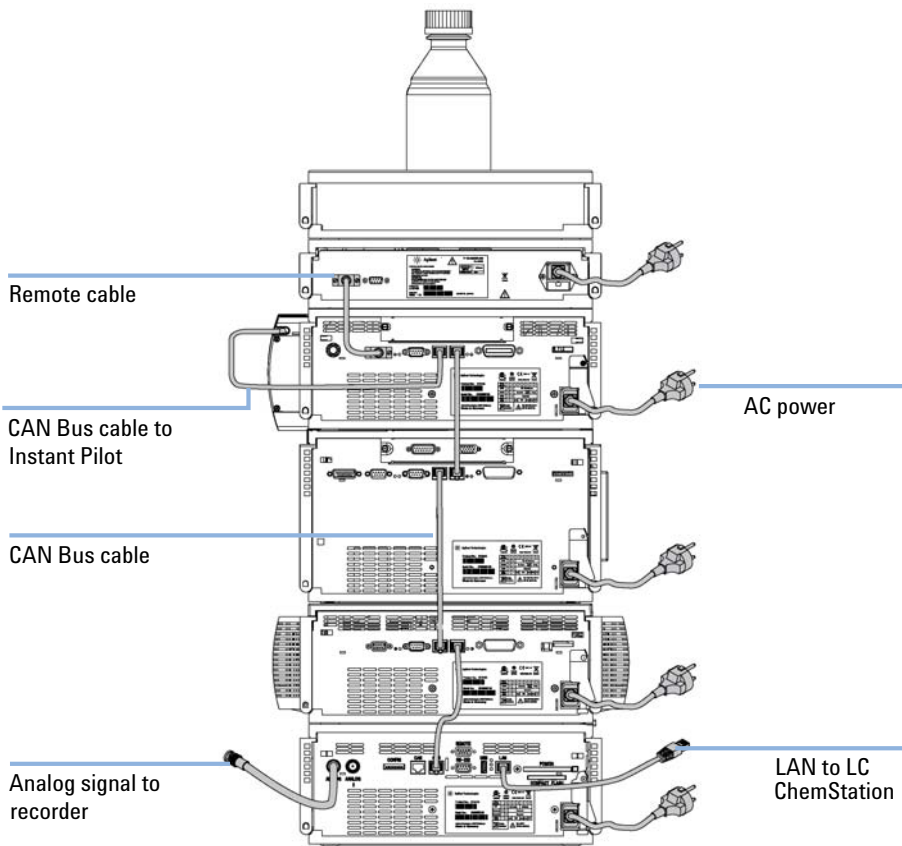

Figure 10 Recommended Stack Configuration for an Autosampler (Rear View)

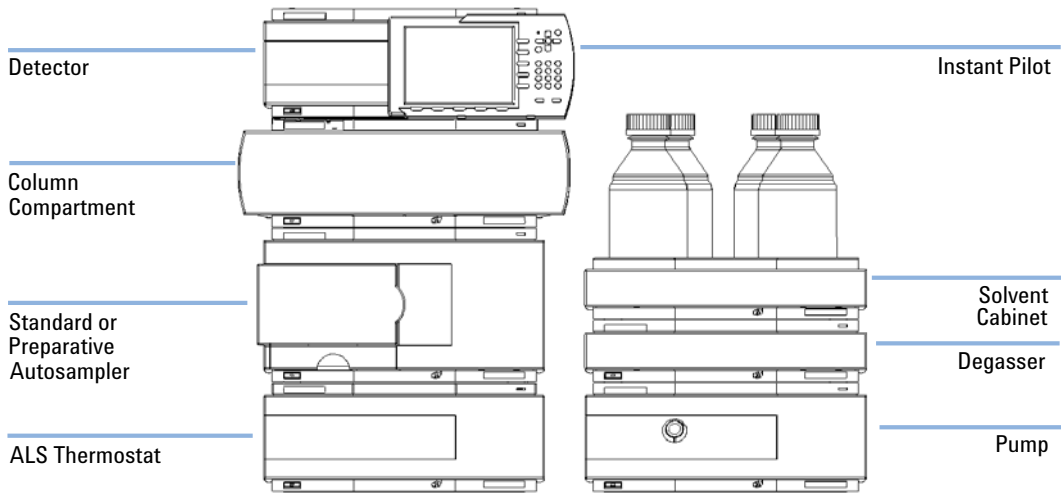

Figure 11 Recommended Stack Configuration for a thermostatted ALS (Front View)

3 Installing the Autosampler

Optimizing the Stack Configuration

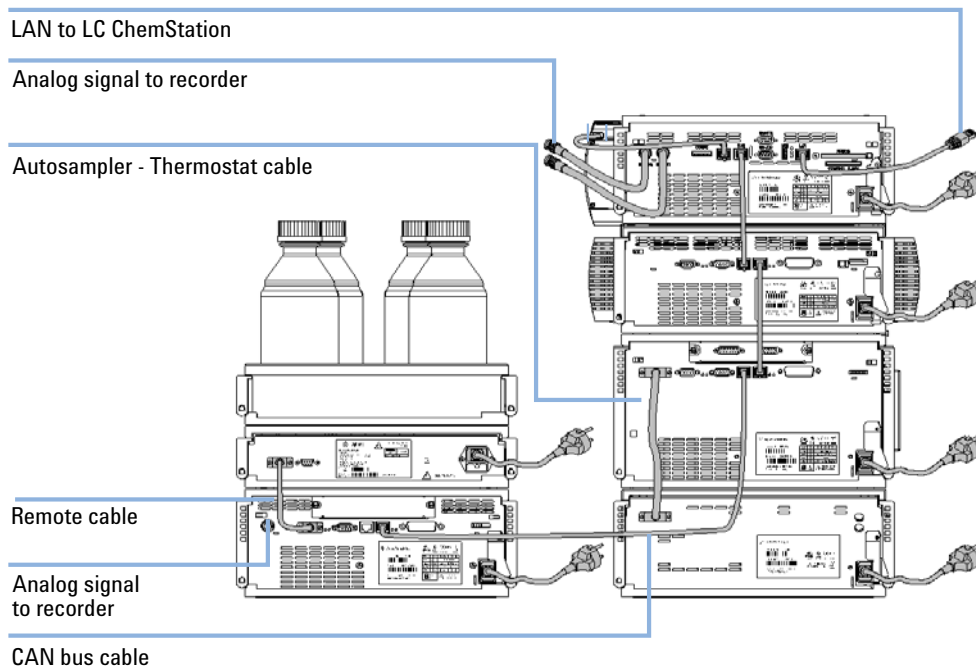

Figure 12 Recommended Stack Configuration for a thermostatted ALS (Rear View)

Installing the Autosampler

Parts required	#	Description
	1	Sampler
	1	Power cord, for the other cables see below and “Cable Overview” on page 120
	1	Control Software (ChemStation, EZChrom, OL, etc.) and/or Control Module G1323B

Preparations	
	<ul style="list-style-type: none"> • Locate bench space • Provide power connection • Unpack the Sampler

WARNING

Module is partially energized when switched off, as long as the power cord is plugged in.

Risk of stroke and other personal injury. Repair work at the module can lead to personal injuries, e. g. shock hazard, when the module cover is opened and the instrument is connected to power.

- Never perform any adjustment, maintenance or repair of the module with the top cover removed and with the power cord plugged in.
- The security lever at the power input socket prevents that the module cover is taken off when line power is still connected. Never plug the power line back in when cover is removed.

WARNING

Personal injury

To avoid personal injury, keep fingers away from the needle area during autosampler operation.

- Do not bend the safety flap away from its position, or attempt to remove the safety cover (see [Figure 13](#) on page 42).
- Do not attempt to insert or remove a vial from the gripper when the gripper is positioned below the needle.

3 Installing the Autosampler

Installing the Autosampler

CAUTION

“Defective on arrival” problems

If there are signs of damage to the autosampler, please do not attempt to install the autosampler. Inspection by Agilent is required to evaluate if the instrument is in good condition or damaged.

- Notify your Agilent sales and service office about the damage.
- An Agilent service representative will inspect the instrument at your site and initiate appropriate actions.

- 1 Install the LAN interface board in the sampler (if required).

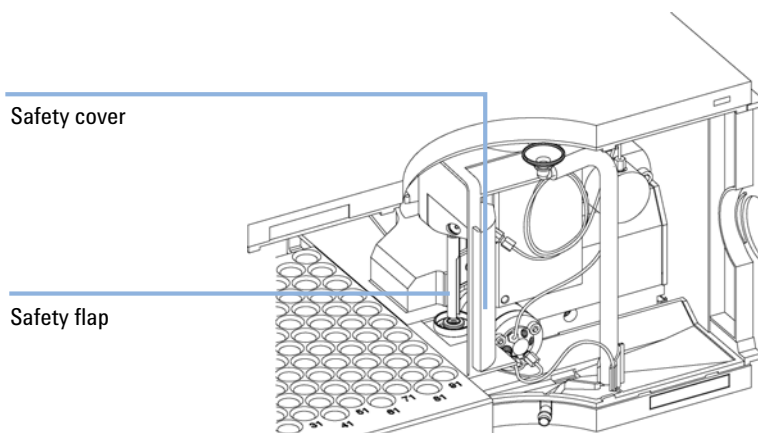

Figure 13 Safety Flap

- 2 Remove the adhesive tape which covers the front door.
- 3 Remove the front door and remove the transport protection foam.
- 4 Place the Autosampler on the bench or in the stack as recommended in [“Optimizing the Stack Configuration”](#) on page 37.
- 5 Ensure the power switch at the front of the Autosampler is OFF.
- 6 Connect the power cable to the power connector at the rear of the sampler.
- 7 Connect the CAN cable to the other Agilent 1200 Series modules.
- 8 If an Agilent Chemstation is the controller, connect either
 - The GPIB cable to the detector

- The LAN connector to the LAN interface
- 9 Connect the APG remote cable (optional) for non Agilent 1200 Series instruments.
 - 10 Turn ON power by pushing the button at the lower left hand side of the sampler.

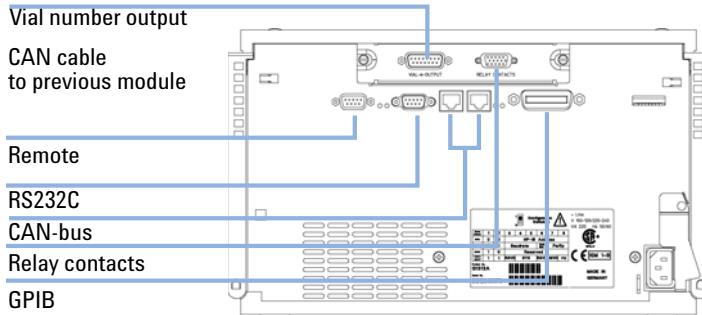

Figure 14 Cable Connections

NOTE

If the front cover is not installed the autosampler is in a not ready condition and operation is inhibited.

NOTE

The sampler is turned ON when the line power switch is pressed and the green indicator lamp is illuminated. The detector is turned OFF when the line power switch is protruding and the green light is OFF.

Installing the Thermostatted Autosampler

Parts required	#	Description
	1	Sampler and Thermostat
	1	Power cord, for the other cables see below and “Cable Overview” on page 120
	1	Control Software (ChemStation, EZChrom, OL, etc.) and/or Control Module G1323B.

Preparations	
	<ul style="list-style-type: none">• Locate bench space• Provide power connection• Unpack the Sampler and the Thermostat

WARNING

Module is partially energized when switched off, as long as the power cord is plugged in.

Risk of stroke and other personal injury. Repair work at the module can lead to personal injuries, e. g. shock hazard, when the module cover is opened and the instrument is connected to power.

- Never perform any adjustment, maintenance or repair of the module with the top cover removed and with the power cord plugged in.
- The security lever at the power input socket prevents that the module cover is taken off when line power is still connected. Never plug the power line back in when cover is removed.

WARNING

Damaged electronics

Disconnecting or reconnecting the autosampler to ALS thermostat cable when the power cords are connected to either of the two modules will damage the electronics of the modules.

- Make sure the power cords are unplugged before disconnecting or reconnecting the autosampler to ALS thermostat cable.

WARNING

Personal injury

To avoid personal injury, keep fingers away from the needle area during Autosampler operation.

→ Do not attempt to insert or remove a vial or a plate when the needle is positioned.

WARNING

Damage through condensation

If the condensation tube is located in liquid the condensed water cannot flow out of the tube and the outlet is blocked. Any further condensation will then remain in the instrument. This may damage the instruments electronics.

→ Make sure that the condensation tube is always above the liquid level in the vessel.

- 1 Place the Thermostat on the bench.
- 2 Remove the front cover and route the condensation drain tube to the waste.

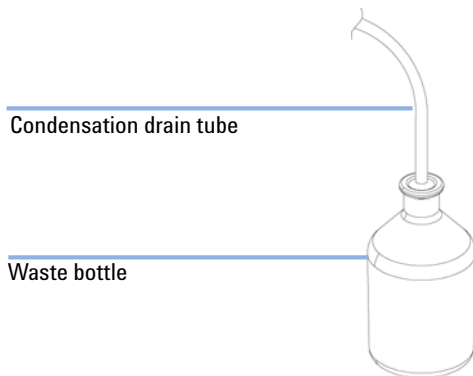

Figure 15 Condensation Leak outlet

- 3 Remove the adhesive tape which covers the front door.
- 4 Remove the front door and remove the transport protection foam.
- 5 Place the Autosampler on top of the Thermostat. Make sure that the Autosampler is correctly engaged in the Thermostat locks.

3 Installing the Autosampler

Installing the Thermostatted Autosampler

- 6 Place the air channel adapter into the autosampler tray base. Make sure the adapter is fully pressed down. This assures that the cold airstream from the Thermostat is correctly guided to the tray area of the Autosampler.

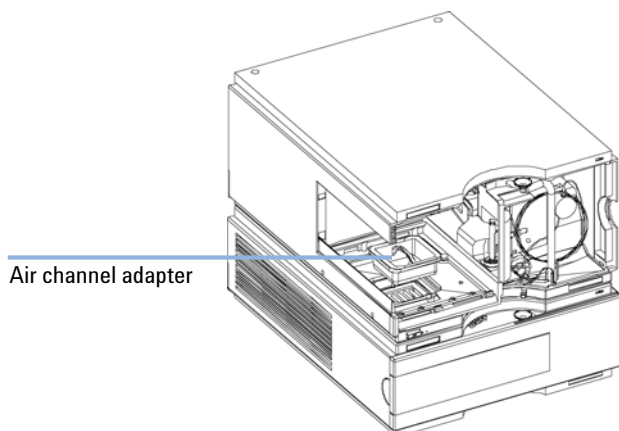

Figure 16 Air channel adapter

- 7 Re-install the tray
- 8 Ensure the power switch on the front of the Autosampler is OFF and the power cables are disconnected.
- 9 Connect the cable between the Autosampler and the Thermostat, see [Figure 17](#) on page 47.
- 10 Connect the power cables to the power connectors.
- 11 Connect the CAN cable to the other Agilent 1200 Series modules.
- 12 If an Agilent ChemStation is the controller, connect either
 - The GPIB cable to the detector
 - The LAN connector to the LAN interface
- 13 Connect the APG remote cable (optional) for non Agilent 1200 Series instruments.
- 14 Turn ON power by pushing the button at the lower left hand side of the sampler.

NOTE

The sampler is turned ON when the line power switch is pressed and the green indicator lamp is illuminated. The detector is turned OFF when the line power switch is protruding and the green light is OFF.

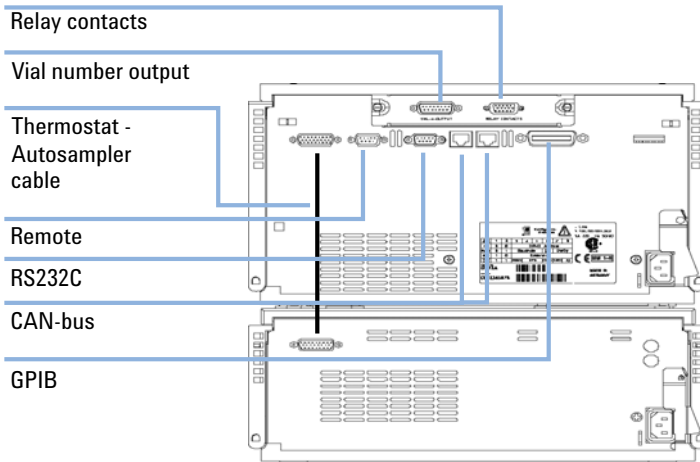

Figure 17 Cable Connections

Flow Connections

Parts required	#	Description
	1	Parts from the Accessory kit
Preparations		<ul style="list-style-type: none">• Sampler is installed in the LC system

WARNING

Toxic and hazardous solvents

The handling of solvents and reagents can hold health risks.

- When opening capillary or tube fittings solvents may leak out.
- Please observe appropriate safety procedures (for example, goggles, safety gloves and protective clothing) as described in the material handling and safety data sheet supplied by the solvent vendor, especially when toxic or hazardous solvents are used.

-
- 1 Connect the pump outlet capillary to port 1 of the injection valve.
 - 2 Connect column-compartment inlet capillary to port 6 of the injection valve.
 - 3 Connect the corrugated waste tube to the solvent waste from the leak plane.
 - 4 Ensure that the waste tube is positioned inside the leak channel.

NOTE

Do not extend the waste capillary of the autosampler. The siphoning effect might empty the complete seat capillary introducing air into the system.

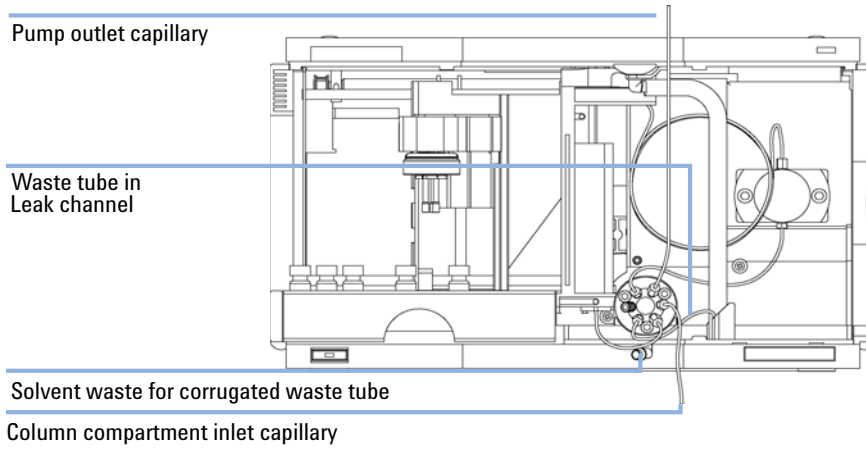

Figure 18 Hydraulic Connections

Installing the Sample Tray

- 1 Open the front door.
- 2 Load the sample tray with sample vials as required.
- 3 Slide the sample tray into the autosampler so that the rear of the sample tray is seated firmly against the rear of the sample-tray area.
- 4 Press the front of the sample tray down to secure the tray in the autosampler.

NOTE

If the thermostatted autosampler tray pops out of position the air channel adapter is not inserted correctly.

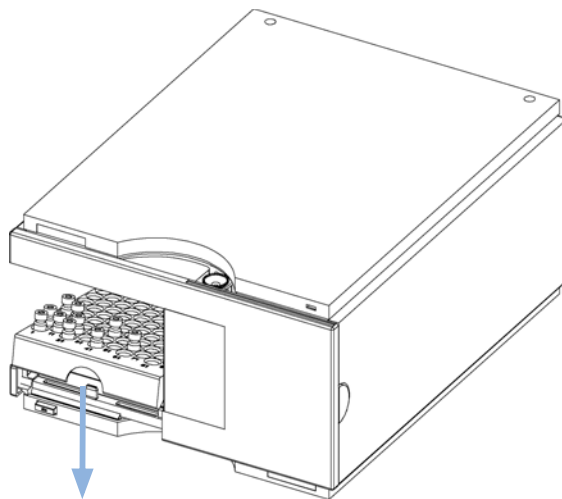

Figure 19 Installing the Sample Tray

Transporting the Autosampler

When moving the autosampler around the laboratory, no special precautions are needed. However, if the autosampler needs to be shipped to another location via carrier, ensure:

- The transport assembly is parked;
- The vial tray is secured.

If the autosampler is to be shipped to another location, the transport assembly must be moved to the park position to prevent mechanical damage should the shipping container be subjected to excessive shock. Also, ensure the vial tray is secured in place with suitable packaging, otherwise the tray may become loose and damage internal components.

3 Installing the Autosampler

Transporting the Autosampler



4 Using the Autosampler

Solvent Information 54

Sample Trays 56

Choice of Vials and Caps 58



Solvent Information

Observe the following recommendations on the use of solvents.

Flow Cell

Avoid the use of alkaline solutions (pH > 9.5) which can attack quartz and thus impair the optical properties of the flow cell.

Prevent any crystallization of buffer solutions. This will lead into a blockage/damage of the flow cell.

If the flow cell is transported while temperatures are below 5 °C, it must be assured that the cell is filled with alcohol.

Aqueous solvents in the flow cell can build up algae. Therefore do not leave aqueous solvents sitting in the flow cell. Add small % of organic solvents (e.g. Acetonitrile or Methanol ~5%).

Solvents

Brown glass ware can avoid growth of algae.

Always filter solvents, small particles can permanently block the capillaries. Avoid the use of the following steel-corrosive solvents:

- Solutions of alkali halides and their respective acids (for example, lithium iodide, potassium chloride, and so on).
- High concentrations of inorganic acids like nitric acid, sulfuric acid especially at higher temperatures (replace, if your chromatography method allows, by phosphoric acid or phosphate buffer which are less corrosive against stainless steel).
- Halogenated solvents or mixtures which form radicals and/or acids, for example:

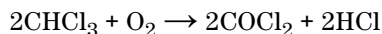

This reaction, in which stainless steel probably acts as a catalyst, occurs quickly with dried chloroform if the drying process removes the stabilizing alcohol.

- Chromatographic grade ethers, which can contain peroxides (for example, THF, dioxane, di-isopropylether). Such ethers should be filtered through dry aluminium oxide which adsorbs the peroxides.
- Solutions of organic acids (acetic acid, formic acid, and so on) in organic solvents. For example, a 1% solution of acetic acid in methanol will attack steel.
- Solutions containing strong complexing agents (for example, EDTA, ethylene diamine tetra-acetic acid).
- Mixtures of carbon tetrachloride with 2-propanol or THF.

Sample Trays

Supported trays for the different Autosampler

Table 11 Supported trays for the Autosampler (G1329A/ G2260A)

Description	Part Number
Tray for 100 x 2 ml vials	G1313-44510
Halftray for 15 x 6 ml vials	G1313-44513
Halftray for 40 x 2 ml vials	G1313-44512
Thermostatable Tray for 100 x 2 ml vials	G1329-60011
Halftray for 15 x 6 ml vials (for G2260A only ¹)	G1313-44513

¹ This tray is not recommended when using a thermostat

Half-Tray Combinations

Half-trays can be installed in any combination enabling both 2 ml-and 6 ml-vials to be used simultaneously.

Numbering of Vial Positions

The standard 100-vial tray has vial positions 1 to 100. However, when using two half-trays, the numbering convention is slightly different. The vial positions of the right-hand half tray begin at position 101 as follows:

Left-hand 40-position tray: 1 - 40

Left-hand 15-position tray: 1-15

Right-hand 40-position tray: 101-140

Right-hand 15-position tray: 101-115

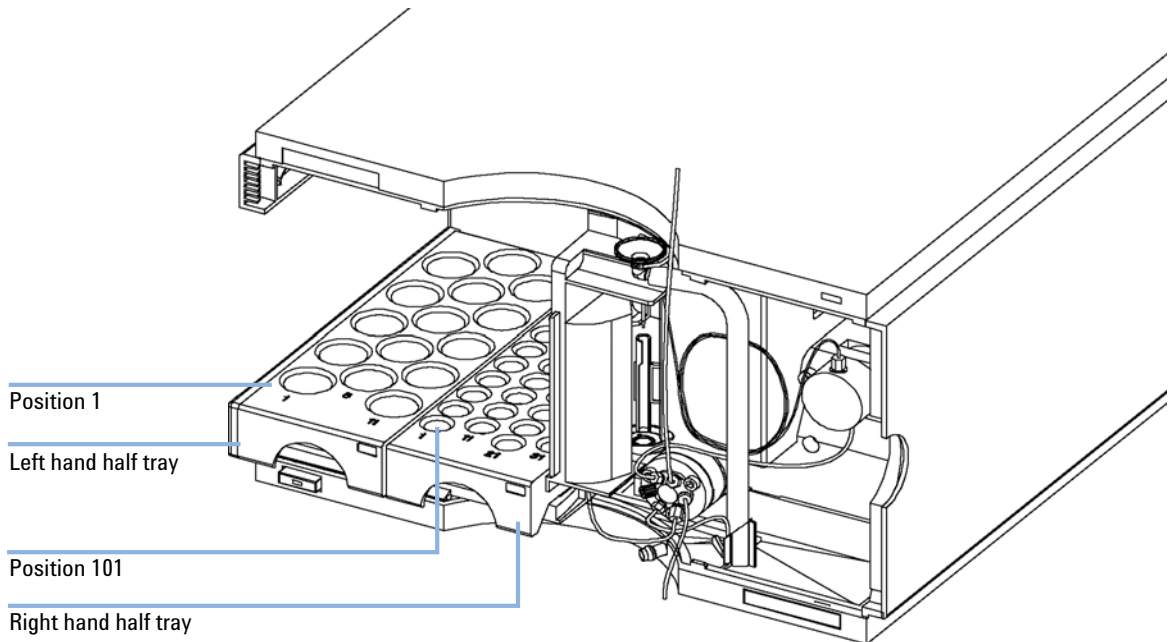

Figure 20 Numbering of Tray Positions

Choice of Vials and Caps

List of Compatible Vials and Caps

For reliable operation vials used with the Agilent 1200 Series autosampler must not have tapered shoulders or caps that are wider than the body of the vial. The vials in [Table 12](#) on page 58, [Table 13](#) on page 58 and [Table 14](#) on page 59 and caps in [Table 15](#) on page 59, [Table 16](#) on page 59 and [Table 17](#) on page 60 (shown with their Part numbers) have been successfully tested using a minimum of 15,000 injections with the Agilent 1200 Series autosampler.

Table 12 Crimp Top Vials

Description	Volume (ml)	100/Pack	1000/Pack	100/Pack (silanized)
Clear glass	2	5181-3375	5183-4491	
Clear glass, write-on spot	2	5182-0543	5183-4492	5183-4494
Amber glass, write-on spot	2	5182-3376	5183-4493	5183-4495
Polypropylene, wide opening	1	5182-0567		5183-4496
Polypropylene, wide opening	0.3		9301-0978	

Table 13 Snap Top Vials

Description	Volume (ml)	100/Pack	1000/Pack	100/Pack (silanized)
Clear glass	2	5182-0544	5183-4504	5183-4507
Clear glass, write-on spot	2	5182-0546	5183-4505	5183-4508
Amber glass, write-on spot	2	5182-0545	5183-4506	5183-4509

Table 14 Screw Top Vials

Description	Volume (ml)	100/Pack	1000/Pack	100/Pack (silanized)
Clear glass	2	5182-0714	5183-2067	5183-2070
Clear glass, write-on spot	2	5182-0715	5183-2068	5183-2071
Amber glass, write-on spot	2	5182-0716	5183-2069	5183-2072

Table 15 Crimp Caps

Description	Septa	100/Pack
Silver aluminum	Clear PTFE/red rubber	5181-1210
Silver aluminum	Clear PTFE/red rubber	5183-4498 (1000/Pack)
Blue aluminum	Clear PTFE/red rubber	5181-1215
Green aluminum	Clear PTFE/red rubber	5181-1216
Red aluminum	Clear PTFE/red rubber	5181-1217

Table 16 Snap Caps

Description	Septa	100/Pack
Clear polypropylene	Clear PTFE/red rubber	5182-0550
Blue polypropylene	Clear PTFE/red rubber	5182-3458
Green polypropylene	Clear PTFE/red rubber	5182-3457
Red polypropylene	Clear PTFE/red rubber	5182-3459

4 Using the Autosampler

Choice of Vials and Caps

Table 17 Screw Caps

Description	Septa	100/Pack
Blue polypropylene	Clear PTFE/red rubber	5182-0717
Green polypropylene	Clear PTFE/red rubber	5182-0718
Red polypropylene	Clear PTFE/red rubber	5182-0719
Blue polypropylene	Clear PTFE/silicone	5182-0720
Green polypropylene	Clear PTFE/silicone	5182-0721
Red polypropylene	Clear PTFE/silicone	5182-0722

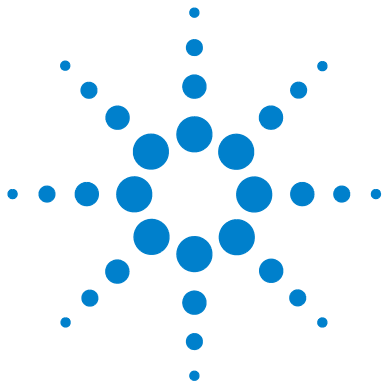

5 Optimizing Performance

Optimization for Lowest Carry-over	62
Using the Automated Needle Wash	63
Using an Injector Program	64
General Recommendation to Lowest Carry-over	65
Fast Injection Cycle and Low Delay Volume	66
Overlapped Injection Mode	66
General Recommendations for Fast Injection Cycle Times	67
Precise Injection Volume	68
Draw and Eject Speed	68
Choice of Rotor Seal	70



Optimization for Lowest Carry-over

Several parts of an injection system can contribute to carry-over:

- needle outside
- needle inside
- needle seat
- sample loop
- seat capillary
- injection valve

The autosampler continuous flow-through design ensures that sample loop, needle inside, seat capillary, and the mainpass of the injection valve is always in the flow line. These parts are continuously flushed during an isocratic and also during a gradient analysis. The residual amount of sample remaining on the outside of the needle after injection may contribute to carry-over in some instances. When using small injection volumes or when injecting samples of low concentration immediately after samples of high concentration, carry-over may become noticeable. Using the automated needle wash enables the carry-over to be minimized and prevents also contamination of the needle seat.

Using the Automated Needle Wash

The automated needle wash can be programmed either as “injection with needle wash” or the needle wash can be included into the injector program. When the automated needle wash is used, the needle is moved into a wash vial after the sample is drawn. By washing the needle after drawing a sample, the sample is removed from the surface of the needle immediately.

Uncapped Wash Vial

For best results, the wash vial should contain solvent in which the sample components are soluble, and the vial should *not* be capped. If the wash vial is capped, small amounts of sample remain on the surface of the septum, which may be carried on the needle to the next sample.

Injector Program with Needle Wash

The injector program includes the command NEEDLE WASH. When this command is included in the injector program, the needle is lowered once into the specified wash vial before injection.

For example:

```
1 DRAW 5 µl
2 NEEDLE WASH vial 7
3 INJECT
```

Line 1 draws 5 µl from the current sample vial. Line 2 moves the needle to vial 7. Line 3 injects the sample (valve switches to main pass).

Using an Injector Program

The process is based on a program that switches the bypass groove of the injection valve into the flow line for cleaning. This switching event is performed at the end of the equilibration time to ensure that the bypass groove is filled with the start concentration of the mobile phase. Otherwise the separation could be influenced, especially if microbore columns are used.

For example:

Outside wash of needle in vial 7 before injection

Injector program:

Draw x.x (y) µl from sample

NEEDLE WASH vial 7

Inject

Wait (equilibration time - see text above)

Valve bypass

Wait 0.2 min

Valve mainpass

Valve bypass

Valve mainpass

NOTE

Overlapped injection together with additional injection valve switching is not possible.

General Recommendation to Lowest Carry-over

- For samples where needle outside cannot be cleaned sufficiently with water or alcohol use wash vials with an appropriate solvent. Using an injector program and several wash vials can be used for cleaning.

In case the needle seat has got contaminated and carry-over is significantly higher than expected, the following procedure can be used to clean the needle seat:

- Go to MORE INJECTOR and set needle to home position.
- Pipette an appropriate solvent on to the needle seat. The solvent should be able to dissolve the contamination. If this is not known use 2 or 3 solvents of different polarity. Use several milliliters to clean the seat.
- Clean the needle seat with a tissue and remove all liquid from it.
- RESET the injector.

Fast Injection Cycle and Low Delay Volume

Short injection cycle times for high sample throughput is one of the most important requirements in analytical laboratories. In order to shorten cycle times, you can:

- shorten the column length
- use high flow rates
- apply a steep gradient

Having optimized these parameters, further reduction of cycle times can be obtained using the overlapped injection mode.

Overlapped Injection Mode

In this process, as soon as the sample has reached the column, the injection valve is switched back to bypass and the next injection cycle starts but waits with switching to mainpass until the actual run is finished. You gain the sample preparation time when using this process.

Switching the valve into the bypass position reduces the system delay volume, the mobile phase is directed to the column without passing sample loop, needle and needle seat capillary. This can help to have faster cycle times especially if low flow rates have to be used like it is mandatory in narrow bore and micro bore HPLC.

NOTE

Having the valve in bypass position can increase the carry-over in the system.

The injection cycle times also depend on the injection volume. In identically standard condition, injecting 100 μl instead of 1 μl , increase the injection time by approximately 8 sec. In this case and if the viscosity of the sample allows it, the draw and eject speed of the injection system has to be increased.

NOTE

For the last injection of the sequence with overlapped injections it has to be considered that for this run the injection valve is not switched as for the previous runs and consequently the injector delay volume is not bypassed. This means the retention times are prolonged for the last run. Especially at low flow rates this can lead to retention time changes which are too big for the actual calibration table. To overcome this it is recommended to add an additional "blank" injection as last injection to the sequence.

General Recommendations for Fast Injection Cycle Times

As described in this section, the first step to provide short cycle times are optimizing the chromatographic conditions. If this is done the autosampler parameter should be set to:

- Overlapped injection mode
- Increase of draw and eject speed for large injection volumes
- Add at last run a blank, if overlapped injection is used

To reduce the injection time, the detector balance has to be set to OFF.

Precise Injection Volume

Injection Volumes Less Than 2 μl

When the injection valve switches to the BYPASS position, the mobile phase in the sample loop is depressurized. When the syringe begins drawing sample, the pressure of the mobile phase is decreased further. If the mobile phase is not degassed adequately, small gas bubbles may form in the sample loop during the injection sequence. When using injection volumes $< 2 \mu\text{l}$, these gas bubbles may affect the injection-volume precision. For best injection-volume precision with injection volumes $< 2 \mu\text{l}$, use of the Agilent 1200 Series degasser is recommended to ensure the mobile phase is adequately degassed. Also, using the automated needle wash (see [“Optimization for Lowest Carry-over”](#) on page 62) between injections reduces carry-over to a minimum, further improving the injection volume precision.

Draw and Eject Speed

Draw Speed

The speed at which the metering unit draws sample out of the vial may have an influence on the injection volume precision when using viscous samples. If the draw speed is too high, air bubbles may form in the sample plug, affecting precision. The default draw speed is 200 $\mu\text{l}/\text{min}$ for the autosampler and 1000 $\mu\text{l}/\text{min}$ for the preparative autosampler. This speed is suitable for the majority of applications, however, when using viscous samples, set the draw speed to lower speed for optimum results. A “DRAW” statement in an injector program also uses the draw speed setting which is configured for the autosampler.

Eject Speed

The default eject speed setting is 200 $\mu\text{l}/\text{min}$ for the standard autosampler and 1000 $\mu\text{l}/\text{min}$ for the preparative autosampler. When using large injection volumes, setting the eject speed to a higher value speeds up the injection cycle by shortening the time the metering unit requires to eject solvent at the beginning of the injection cycle (when the plunger returns to the home position).

An “EJECT” statement in an injector program also uses the eject speed setting which is configured for the autosampler. A faster eject speed shortens the time required to run the injector program. When using viscous samples, a high eject speed should be avoided.

Choice of Rotor Seal

Vespe^l™ Seal (for standard valves only)

The standard seal has sealing material made of Vespe^l. Vespe^l is suitable for applications using mobile phases within the pH range of 2.3 to 9.5, which is suitable for the majority of applications. However, for applications using mobile phases with pH below 2.3 or above 9.5, the Vespe^l seal may degrade faster, leading to reduced seal lifetime.

Tefze^l™ Seal (for standard valve only)

For mobile phases with pH below 2.3 or above 9.5, or for conditions where the lifetime of the Vespe^l seal is drastically reduced, a seal made of Tefze^l is available. Tefze^l is more resistant than Vespe^l to extremes of pH, however, is a slightly *softer* material. Under normal conditions, the expected lifetime of the Tefze^l seal is shorter than the Vespe^l seal, however, Tefze^l may have the longer lifetime under more extreme mobile phase conditions.

PEEK Seal (for preparative injection valve only)

The preparative injection valve has a sealing material made of PEEK. This material has high chemical resistance and versatility. It is suitable for application using mobile phases within a pH between 1 and 14.

This seal is also used for the G1329B module.

NOTE

Strong oxidizing acids such as concentrated nitric and sulfuric acids are not compatible with PEEK.



6 Troubleshooting and Diagnostics

Agilent Lab Monitor & Diagnostic Software 72

Overview of the Sampler's Indicators and Test Functions 73



Agilent Lab Monitor & Diagnostic Software

The Agilent Lab Advisor Software is a standalone product that can be used with or without data system. Agilent Lab Advisor helps to manage the lab for high quality chromatographic results and can monitor in real time a single Agilent LC or all the Agilent GCs and LCs configured on the lab intranet.

Agilent Lab Advisor provides diagnostic capabilities for all Agilent 1200 Series HPLC modules. This includes tests and calibrations procedures as well as the different injector steps to perform all the maintenance routines.

Agilent Lab Advisor also allows users to monitor the status of their LC instruments. The Early Maintenance Feedback (EMF) feature helps to carry out preventive maintenance. In addition, users can generate a status report for each individual LC instrument. The tests and diagnostic features as provided by the Agilent Lab Advisor Software may differ from the descriptions in this manual. For details refer to the Agilent Lab Advisor help files.

This manual provides lists with the names of Error Messages, Not Ready messages, and other common issues.

Overview of the Sampler's Indicators and Test Functions

Status Indicators

The autosamplers are provided with two status indicators which indicate the operational state (prerun, run, and error states) of the instrument. The status indicators provide a quick visual check of the operation of the autosampler .

Error Messages

In the event of an electronic, mechanical or hydraulic failure, the instrument generates an error message in the user interface. For details on error messages and error handling, please refer to the Agilent Lab Monitor & Diagnostic Software.

Maintenance Functions

The maintenance functions position the needle arm, gripper assembly, and metering device for easy access when doing maintenance.

Step Commands

The step functions provide the possibility to execute each step of the sampling sequence individually. The step functions are used primarily for troubleshooting, and for verification of correct autosampler operation after repair.

6 Troubleshooting and Diagnostics

Overview of the Sampler's Indicators and Test Functions



7 Maintenance

Introduction into Maintenance and Repair	76
Simple Repairs	76
Exchanging Internal Parts	76
Safety Flap, Flex Board	76
Transport Assembly Parts	76
Updating the Firmware	77
Warnings and Cautions	78
Using the ESD Strap	78
Cleaning the module	79
Overview of Main Repair Procedures	80
Early Maintenance Feedback (EMF)	82
EMF Counters	82
Using the EMF Counters	83
Maintenance Functions	84
Simple Repairs	85
Needle Assembly	86
Needle-Seat Assembly	89
Stator Face	91
Rotor Seal	94
Metering Seal and Plunger	98
Gripper Arm	102
Interface Board	104



Introduction into Maintenance and Repair

Simple Repairs

The autosampler is designed for easy repair. The most frequent repairs such as change and needle assembly change can be done from the front of the instrument with the instrument in place in the system stack. These repairs are described in [Table 18](#) on page 85.

Exchanging Internal Parts

Some repairs may require exchange of defective internal parts. Exchange of these parts requires removing the autosampler from the stack, removing the covers, and disassembling the autosampler.

Safety Flap, Flex Board

It is strongly recommended that the exchange of the safety flap, and flex board is done by Agilent-trained service personnel.

Transport Assembly Parts

The adjustment of the motors, and the tension on the drive belts are important for correct operation of the transport assembly. It is strongly recommended that exchange of drive belts, and the gripper assembly is done by Agilent-trained service personnel. There are no other field-replaceable parts in the transport assembly. If any other component is defective (flex board, spindles, plastic parts) the complete unit must be exchanged.

Updating the Firmware

The Agilent 1200 Series LC modules are fitted with FLASH EPROMS. These EPROMS enable you to update the instrument firmware from the ChemStation, PCMCIA card, or through the RS232 interface. The firmware update procedure is described in the on-line user information.

Warnings and Cautions

WARNING

Module is partially energized when switched off, as long as the power cord is plugged in.

Repair work at the module can lead to personal injuries, e.g. shock hazard, when the cover is opened and the module is connected to power.

- Make sure that it is always possible to access the power plug.
 - Remove the power cable from the instrument before opening the cover.
 - Do not connect the power cable to the Instrument while the covers are removed.
-

Using the ESD Strap

Electronic boards are sensitive to electronic discharge (ESD). In order to prevent damage, always use an ESD kit when handling electronic boards and components. Use the ESD kit according to recommendations given by the supplier.

Cleaning the module

The module case should be kept clean. Cleaning should be done with a soft cloth slightly dampened with water or a solution of water and mild detergent. Do not use an excessively damp cloth as liquid may drip into the module.

WARNING

Liquid dripping into the electronic compartment of your module.

Liquid in the module electronics can cause shock hazard and damage the module.

- Do not use an excessively damp cloth during cleaning.
 - Drain all solvent lines before opening any fittings.
-

Overview of Main Repair Procedures

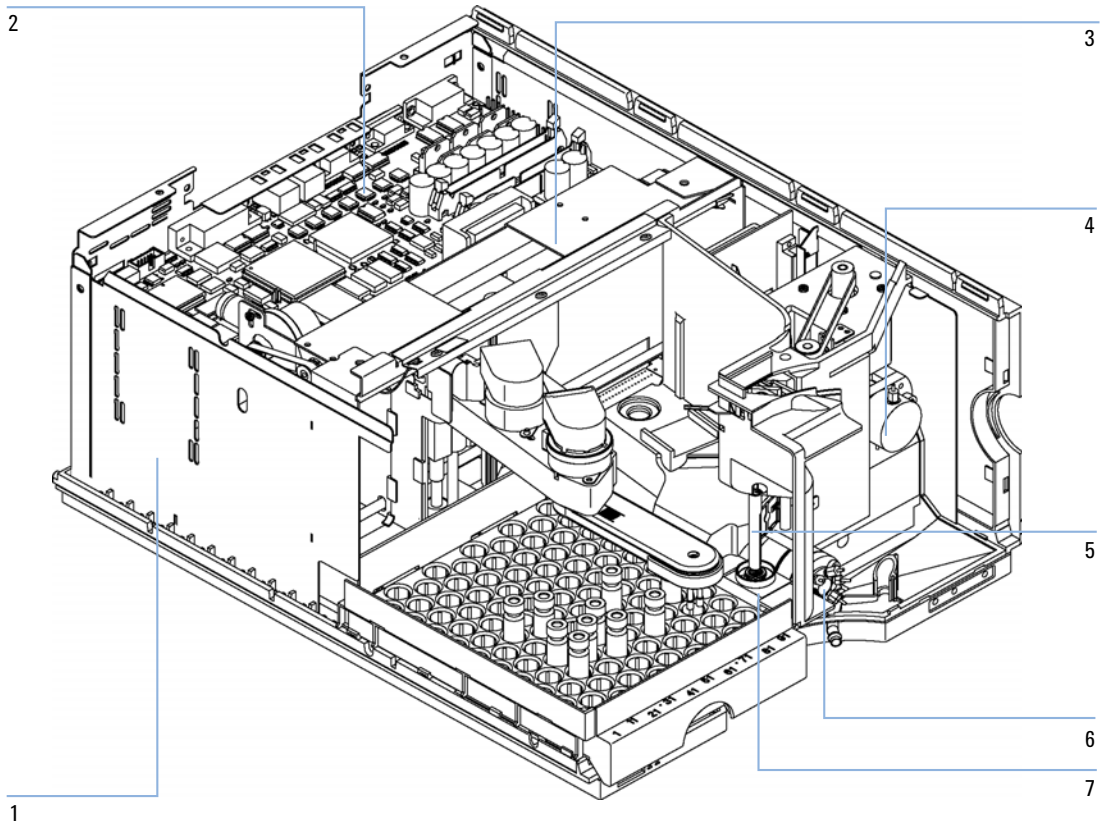

Figure 21 Main Assemblies

1	Power supply
2	ASM board
3	Transport assembly
4	Metering seal, " Metering Seal and Plunger " on page 98
5	Needle, " Needle Assembly " on page 86
6	Rotor seal, " Rotor Seal " on page 94
7	Needle seat, " Needle-Seat Assembly " on page 89

Early Maintenance Feedback (EMF)

Maintenance requires the exchange of components in the flow path which are subject to mechanical wear or stress. Ideally, the frequency at which components are exchanged should be based on the intensity of usage of the instrument and the analytical conditions, and not on a predefined time interval. The early maintenance feedback (EMF) feature monitors the usage of specific components in the instrument, and provides feedback when the user-setable limits have been exceeded. The visual feedback in the user interface provides an indication that maintenance procedures should be scheduled.

EMF Counters

The autosampler provides two EMF counters. Each counter increments with autosampler use, and can be assigned a maximum limit which provides visual feedback in the user interface when the limit is exceeded. Each counter can be reset to zero after maintenance has been done. The autosampler provides the following EMF counters:

Injection valve counter

This counter displays the total number of switches of the injection valve since the last reset of the counter.

Needle Movements Counter

This counter displays the total number of movements of the needle into the seat since the last reset of the counter.

Using the EMF Counters

The user-settable EMF limits for the EMF counters enable the early maintenance feedback to be adapted to specific user requirements. The wear of autosampler components is dependent on the analytical conditions, therefore, the definition of the maximum limits need to be determined based on the specific operating conditions of the instrument.

Setting the EMF Limits

The setting of the EMF limits must be optimized over one or two maintenance cycles. Initially, no EMF limit should be set. When instrument performance indicates maintenance is necessary, make note of the values displayed by the injection valve and needle movements counters. Enter these values (or values slightly less than the displayed values) as EMF limits, and then reset the EMF counters to zero. The next time the EMF counters exceed the new EMF limits, the EMF flag will be displayed, providing a reminder that maintenance needs to be scheduled.

Maintenance Functions

Certain maintenance procedures require the needle arm, metering device, and gripper assembly to be moved to specific positions to enable easy access to components. The maintenance functions move these assemblies into the appropriate maintenance position.

Simple Repairs

The procedures described in this section can be done with the autosampler in place in the stack. You will do some of these procedures on a more frequent basis.

Table 18 Simple Repair Procedures

Procedure	Typical Frequency	Time Required	Notes
Exchanging the needle assembly	When needle shows indication of damage or blockage	15 minutes	See “Needle Assembly” on page 86
Exchanging the seat assembly	When the seat shows indication of damage or blockage	10 minutes	See “Needle-Seat Assembly” on page 89
Exchanging the rotor seal	After approximately 30000 to 40000 injections, or when the valve performance shows indication of leakage or wear	30 minutes	See “Rotor Seal” on page 94
Exchanging the metering seal	When autosampler reproducibility indicates seal wear	30 minutes	See “Metering Seal and Plunger” on page 98
Exchanging the gripper arm	When the gripper arm is defective	10 minutes	See “Gripper Arm” on page 102

Needle Assembly

When When the needle is visibly damaged
When the needle is blocked

Tools required

- ¼ inch wrench (supplied in accessory kit)
- 2.5 mm Hex key (supplied in accessory kit)
- A pair of pliers

Parts required

#	Part number	Description
1	G1313-87201	Needle assembly for G1313-87101 or G1313-87103 needle-seat
1	G1329-80001	Needle assembly for G1329-87101 or G1329-87103 needle seat
1	G1313-87202	Needle assembly (900 µl loop cap) for G1313-87101 needle seat
1	G2260-87201	Needle assembly (900 µl loop cap) for G2260-87101 needle-seat

Preparations

- Select “Start” in the maintenance function “Change Needle”.
- When the needle is positioned approx.15 mm above the needle seat, remove the front cover.

WARNING

Personal injury

To avoid personal injury, keep fingers away from the needle area during autosampler operation.

→ Do not bend the safety flap away from its position, or attempt to insert or remove a vial from the gripper when the gripper is positioned below the needle.

- 1 Select **Needle Down** until the needle screw is aligned with the hole in the safety cover.

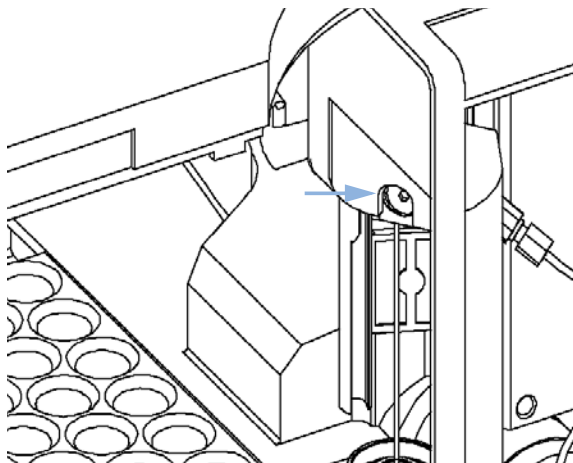

- 2 Remove the sample-loop fitting from the needle fitting.

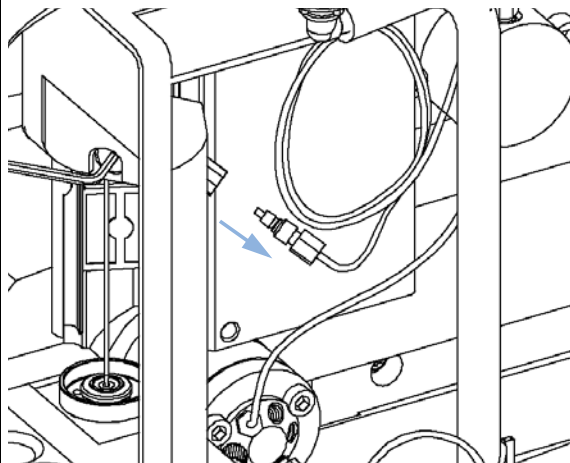

- 3 Loosen the fixing screw, and lift out the needle.

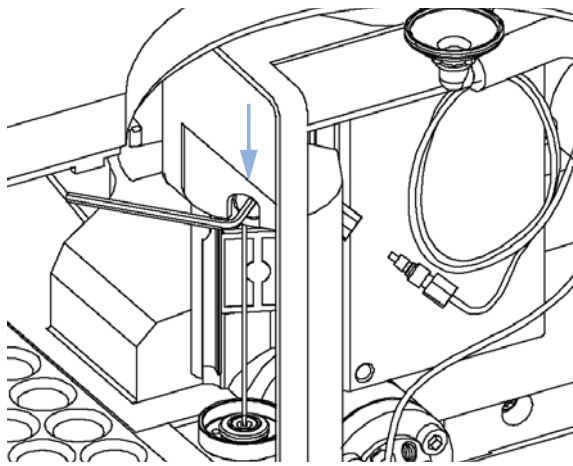

- 4 Insert the new needle. Align the needle in the seat, then tighten the screw firmly.

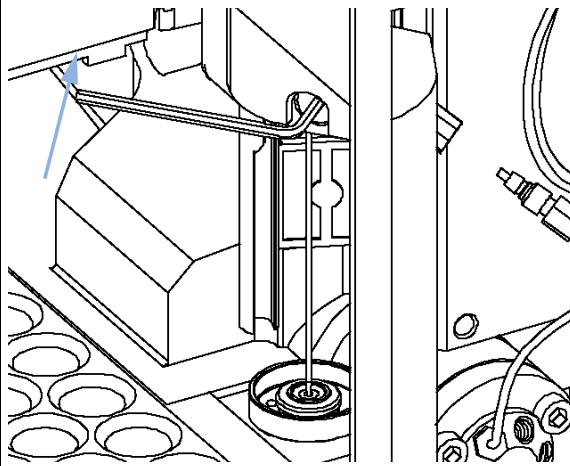

7 Maintenance

Simple Repairs

5 Reconnect the sample-loop fitting to the needle fitting.

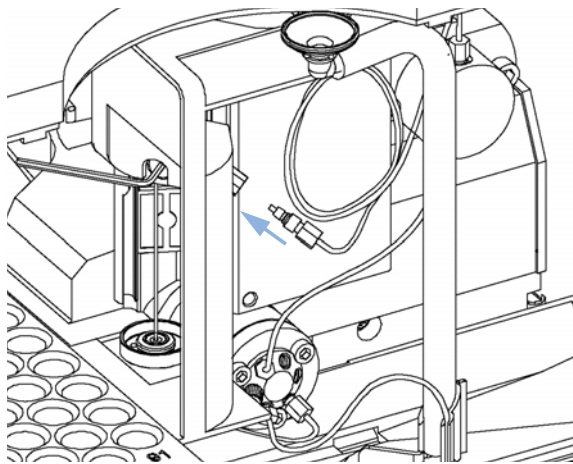

6 Use **Needle Up** to lift the needle to a position approximately 2mm above the seat.

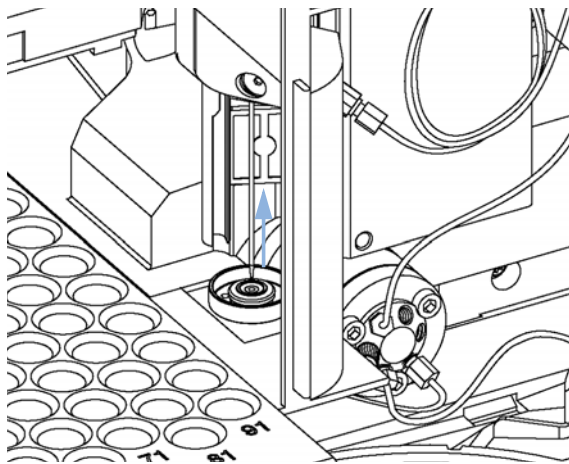

7 Ensure the needle is aligned with the seat.

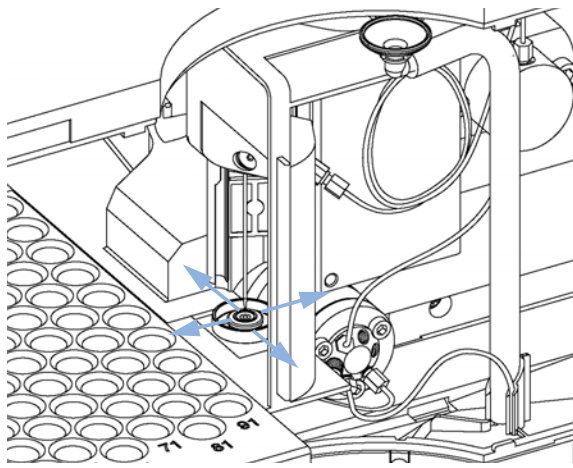

Next Steps:

- 8 On completion of this procedure: Install the front cover.
- 9 Select "End" in the maintenance function "Change Needle".

Needle-Seat Assembly

When When the seat is visibly damaged
When the seat capillary is blocked

Tools required

- 1/4 inch wrench (supplied in accessory kit).
- Flat-head screwdriver.

Parts required	#	Part number	Description
	1	G1313-87101	Needle-seat assy (0.17 mm i.d 2.3 µl) for G1329A/B
	1	G1313-87103	Needle-seat assy (0.12 mm i.d 1.2 µl) for G1329A/B
	1	G2260-87101	Needle-seat assy (0.50 mm i.d 20 µl) for G2260A

Preparations

- Select "Start" in the maintenance function "Change Needle".
- Remove the front cover.
- Use the "Needle Up" command in the "Change Needle" function to lift the needle an addition 1 cm.

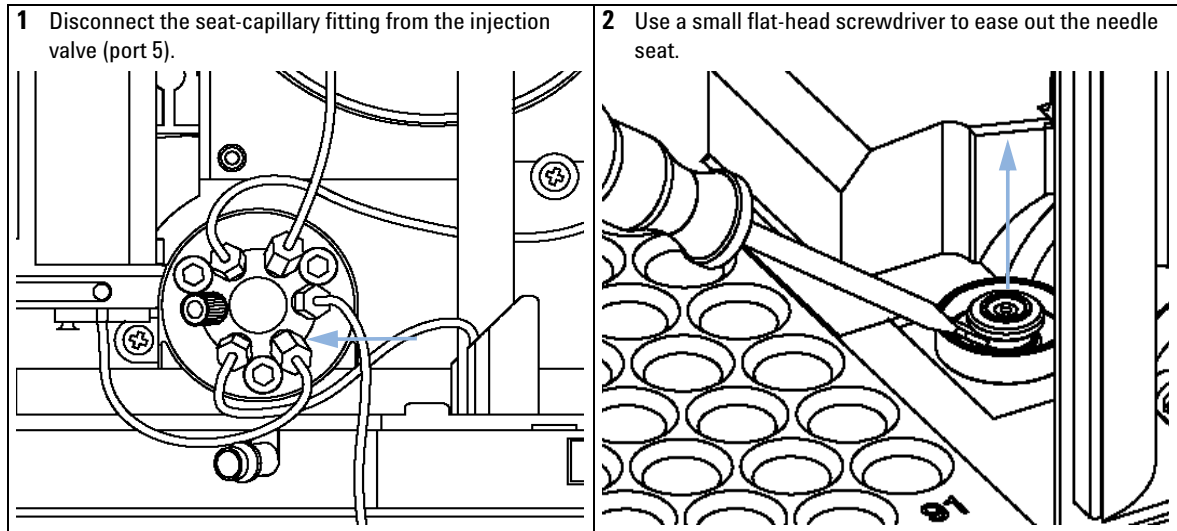

7 Maintenance

Simple Repairs

3 Insert the new needle-seat assembly. Press the seat firmly into position.

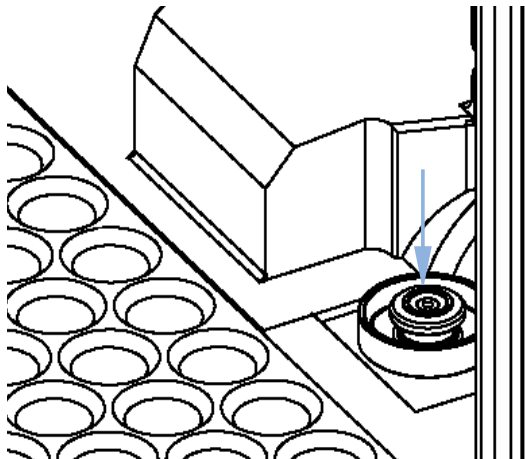

4 Connect the seat-capillary fitting to port 5 of the injection valve.

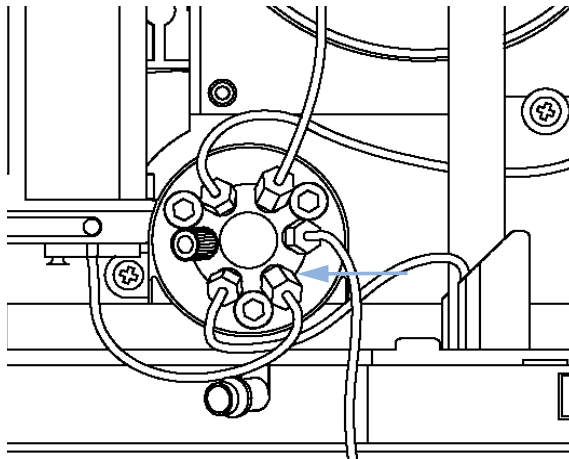

5 Use "Down" to position the needle approximately 2 mm above the seat

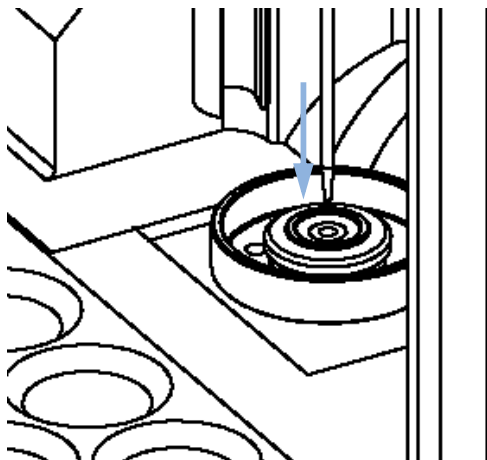

6 Ensure the needle is aligned with the seat. If required, bend the needle slightly until the needle is aligned correctly.

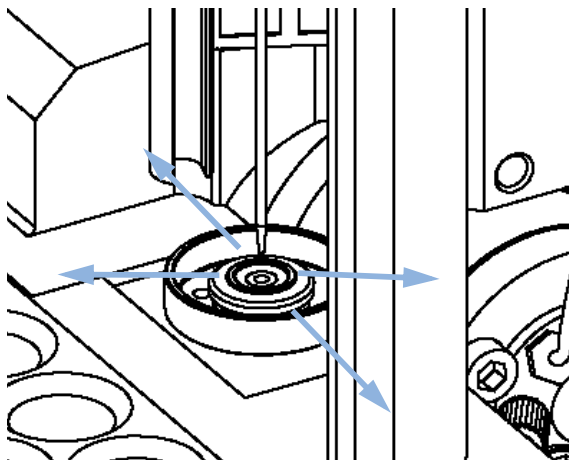

Next Steps:

7 On completion of this procedure: Install the front cover.

8 Select "End" in the maintenance function "Change Needle".

Stator Face

When Poor injection-volume reproducibility
Leaking injection valve

Tools required

- 1/4 inch wrench (supplied in accessory kit)
- Hex key, 9/64 inch (supplied in accessory kit)

Parts required

#	Part number	Description
1	0100-1851	Stator face for G1329A
1		No stator face for G1329B (functionality part of stator head).
1	0101-1268	Stator face for G2260A

Preparations

- Remove the front cover.
- Remove the leak tubings (if necessary).

CAUTION

Removing the stator head

The stator face is held in place by the stator head. When you remove the stator head, the stator face can fall out of the valve.

→ Carefully handle the valve to prevent damage to the stator face

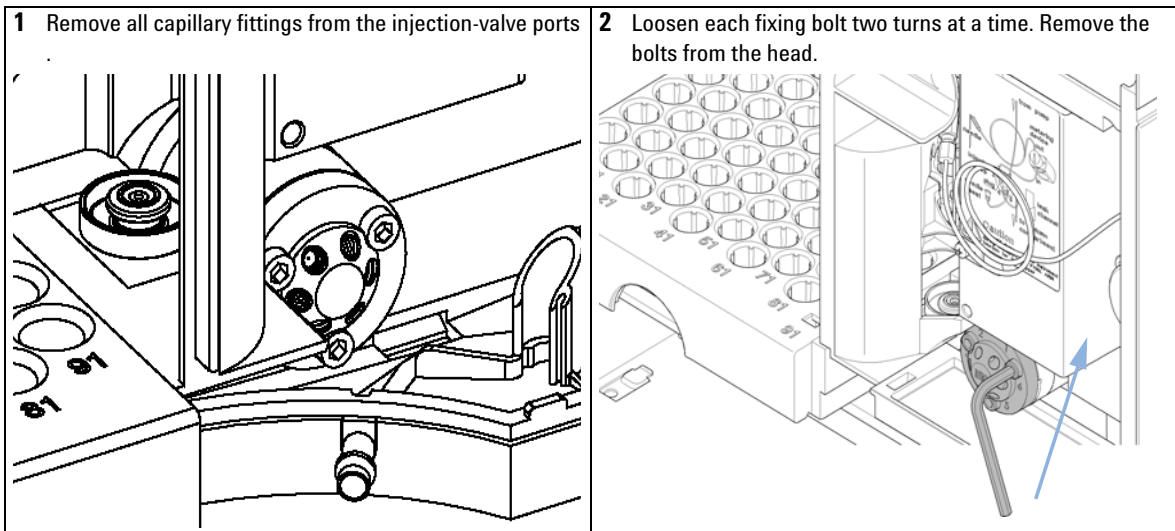

7 Maintenance

Simple Repairs

3 Remove the stator head and stator face.

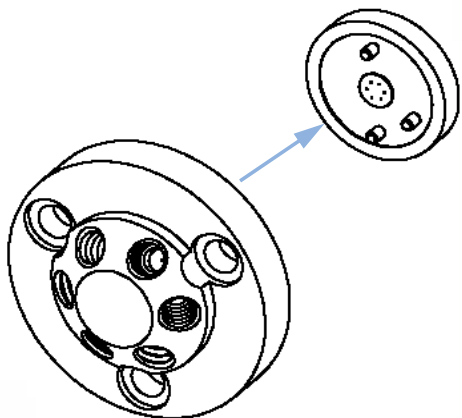

4 Place the stator face in place on the stator head. Ensure the pins on the stator engage in the holes in the stator head.

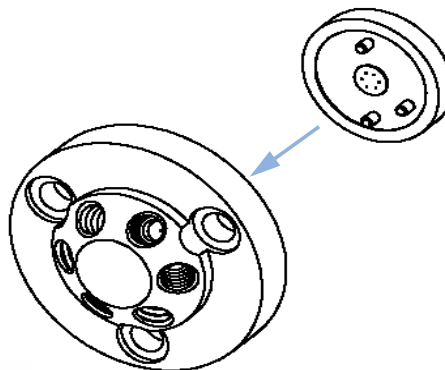

5 Install stator head and stator face. Tighten the bolts alternately two turns at a time until the stator head is secure.

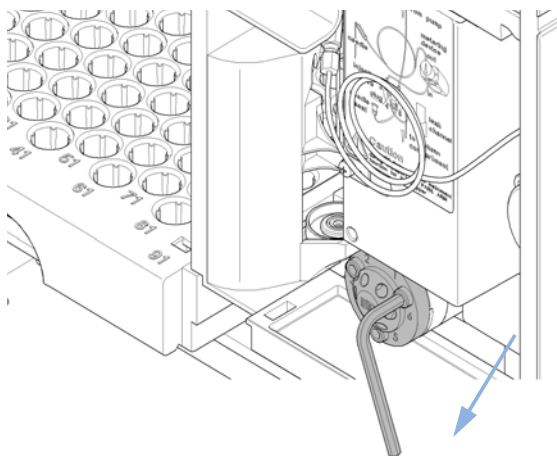

6 Reconnect the pump capillaries to the valve ports (see [Figure 18](#) on page 49).

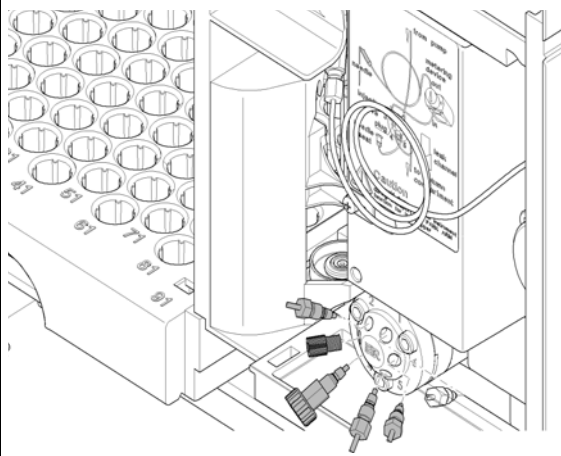

7 Slide the waste tube into the waste holder in the leak tray.

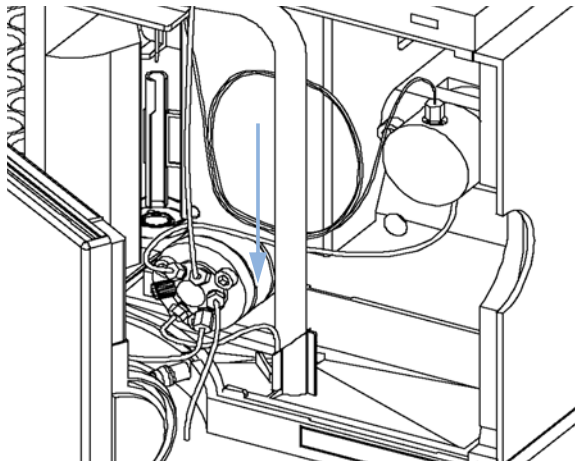

8 On completion of this procedure: Install the front cover.

Rotor Seal

When Poor injection-volume reproducibility
Leaking injection valve

Tools required

- 1/4 inch wrench (supplied in accessory kit).
- Hex key, 9/64 inch (supplied in accessory kit).

Parts required

#	Part number	Description
1	0100-1853	Rotor seal (Vespel) for G1329A
1	0100-1849	Rotor seal (Tefzel) for G1329A
1	0101-1416	Rotor seal (PEEK) for G1329B
1	0101-1268	Rotor seal (PEEK) for G2260A

Preparations

- Remove front cover.
- Remove the leak tubing (if necessary).

CAUTION

Removing the stator head

The stator face is held in place by the stator head. When you remove the stator head, the stator face can fall out of the valve.

→ Carefully handle the valve to prevent damage to the stator face

NOTE

There is no stator face for G1329B.

1 Remove all capillary fittings from the injection-valve ports.

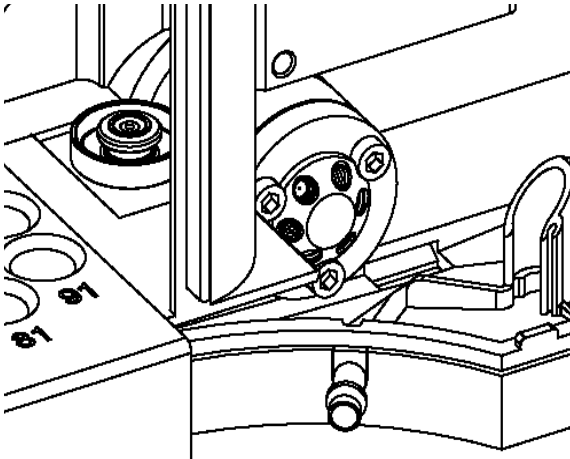

2 Loosen each fixing bolt two turns at a time. Remove the bolts from the head.

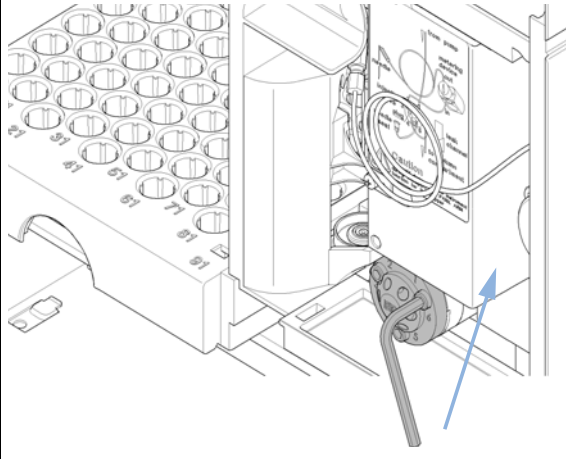

3 Remove the stator head, stator face and stator ring.

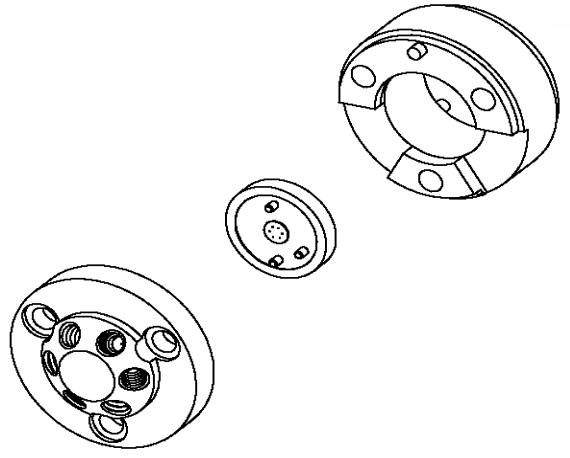

4 Remove the rotor seal and isolation seal.

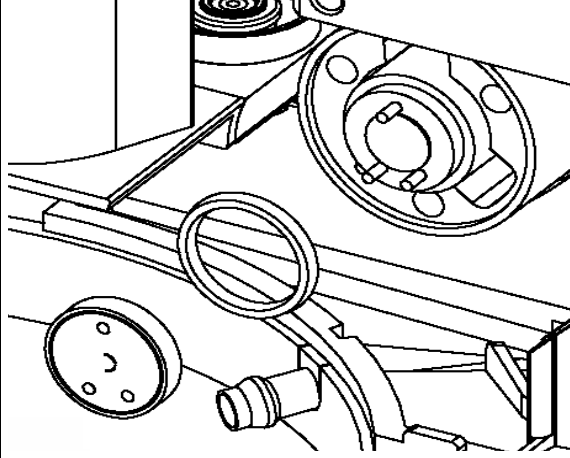

7 Maintenance

Simple Repairs

5 Install the new rotor seal and isolation seal. Ensure the metal spring inside the isolation seal faces towards the valve body.

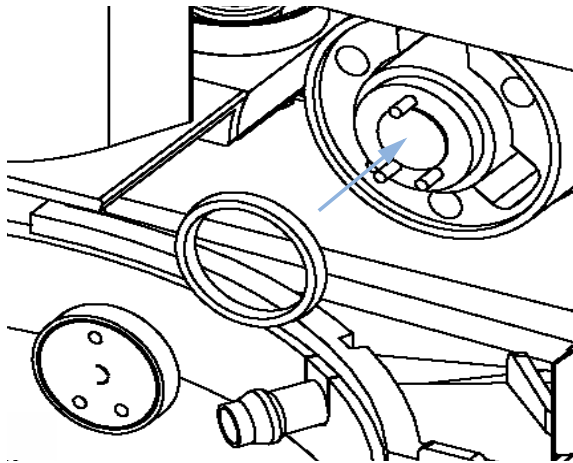

6 Install the stator ring with the short of the two pins facing towards you at the 12 O'Clock position. Ensure the ring sits flat on the valve body.

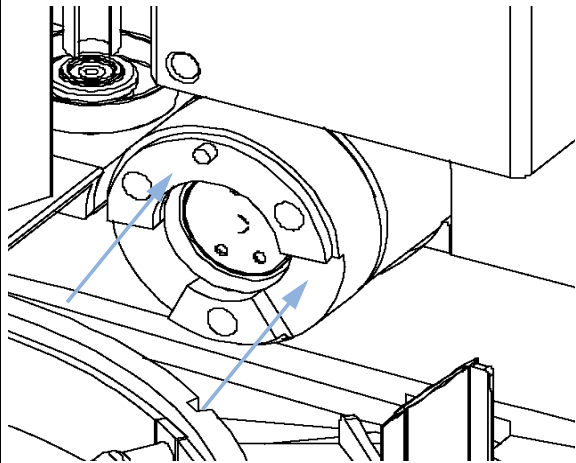

7 Place the stator face in place on the stator head.

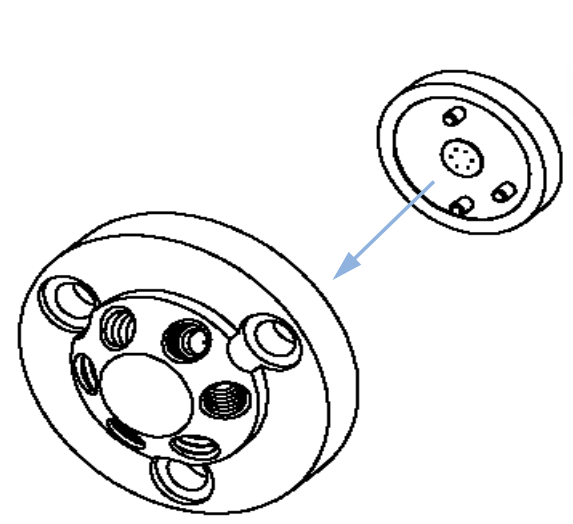

8 Install stator head and stator face. Tighten the bolts alternately two turns at a time until the stator head is secure.

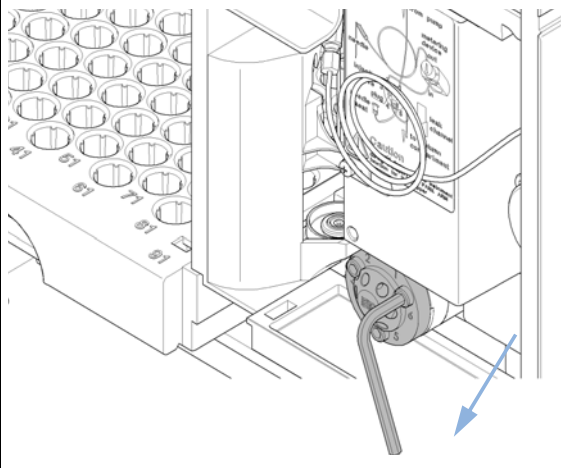

9 Reconnect the pump capillaries to the valve ports (see [Figure 18](#) on page 49).

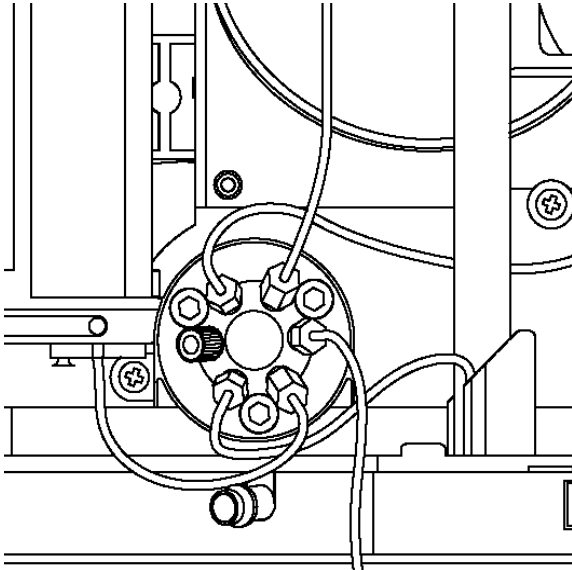

10 Slide the waste tube into the waste holder in the leak tray.

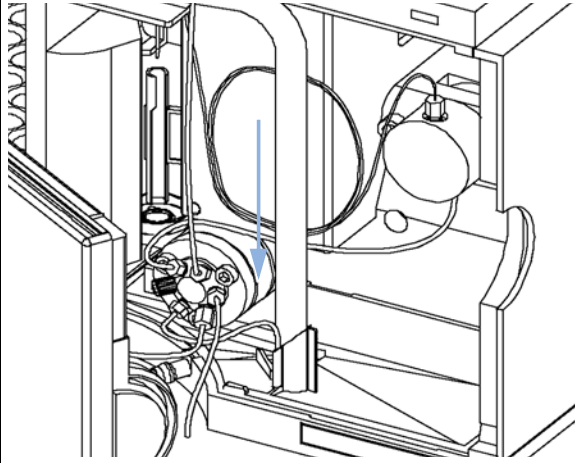

11 On completion of this procedure: Install the front cover.

Metering Seal and Plunger

When Poor injection-volume reproducibility
Leaking metering device

Tools required

- 1/4 inch wrench (supplied in accessory kit).
- 4 mm hex key (supplied in accessory kit).
- 3 mm hex key (supplied in accessory kit).

Parts required	#	Part number	Description
	1	5063-6589	Metering seal (pack of 2) for 100 µl analytical head
	1		Metering seal (pack of 1) for 900 µl analytical head
	1	5063-6586	Metering plunger for 100 µl analytical head
	1	5062-8587	Metering plunger for 900 µl analytical head (only if scratched or contaminated)

Preparations

- Select “Start” in the maintenance function “Change piston”.
- Remove the front cover.

1 Remove the two capillaries from the metering-head assembly.

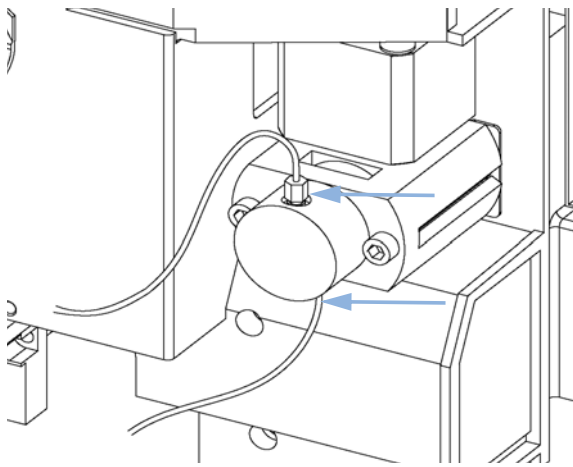

2 Remove the two fixing bolts, and pull the head assembly away from the sampler. Notice that the closed side of the metering head faces upwards.

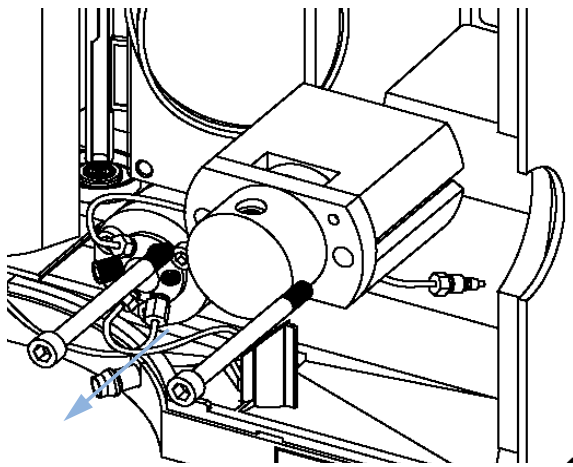

3 Remove the two fixing bolts from the base of the metering head assembly.

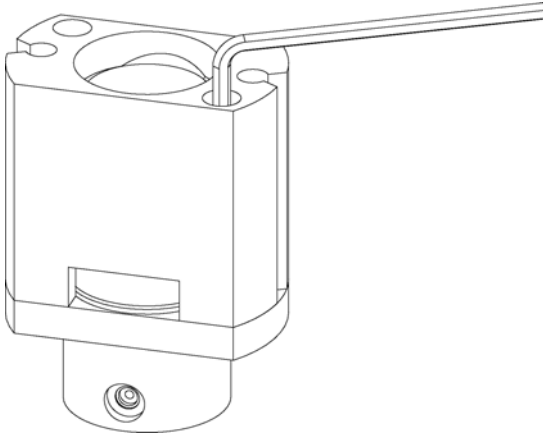

4 Disassemble the metering head assembly.

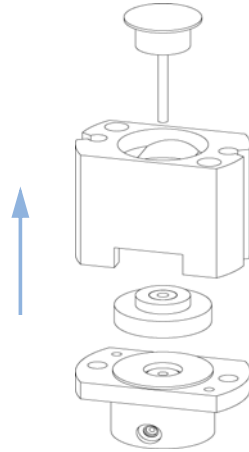

5 Use a small screwdriver to carefully remove the seal. Clean the chamber with lint-free cloth. Ensure all particular matter is removed.

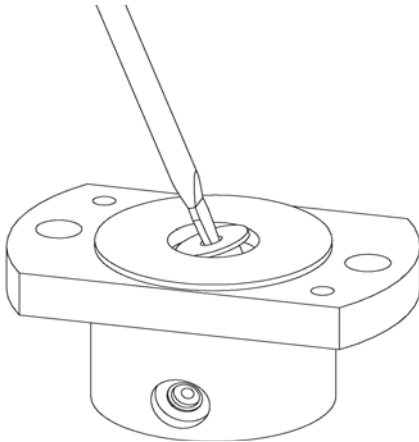

6 Install the new seal. Press the seal firmly into position.

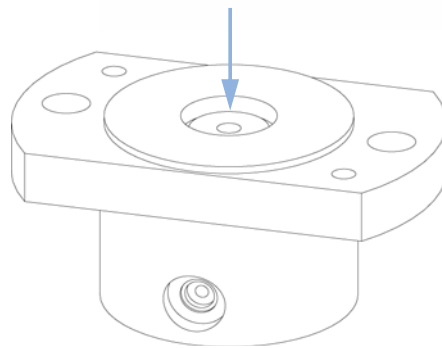

7 Maintenance

Simple Repairs

7 Place the piston guide on top of the seal.

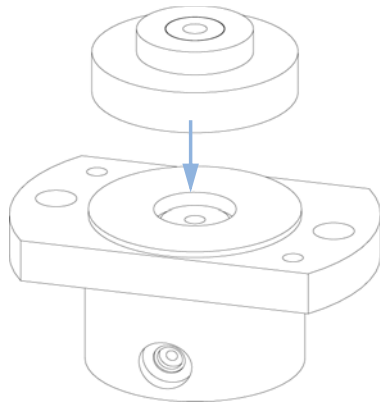

8 Reassemble the metering head assembly. Carefully insert the plunger into the base. The closed side of the metering head must be on the same side as the lower one of the two capillary drillings.

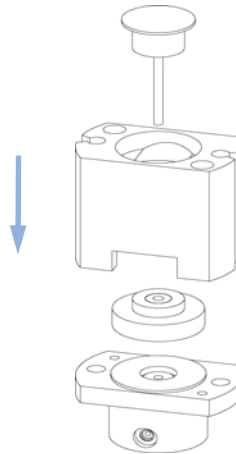

9 Install the fixing bolts. Tighten the bolts securely.

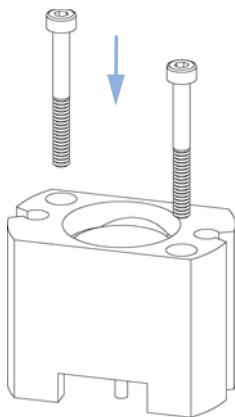

10 Install the metering head assembly in the autosampler. Ensure the large hole in the metering head is facing downwards.

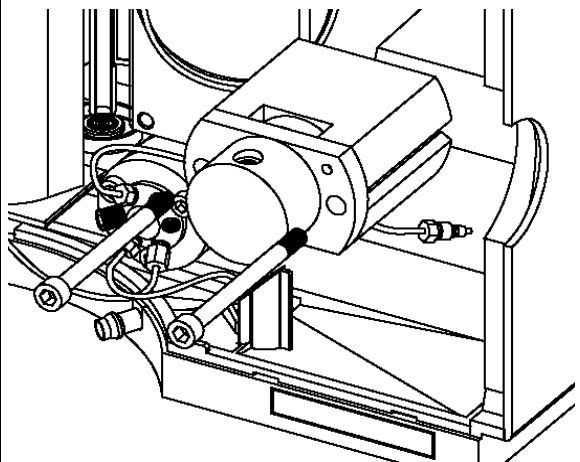

11 Reinstall the capillaries.

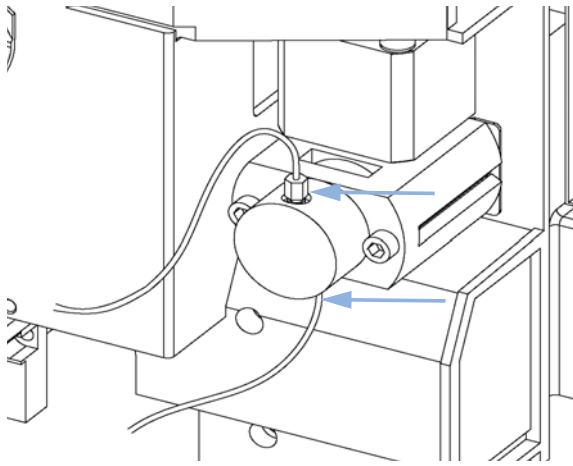

Next Steps:

12 On completion of this procedure: Install the front cover.

13 Select “End” in the maintenance function “Change piston” .

7 Maintenance

Simple Repairs

Gripper Arm

When Defective gripper arm

Tools required • Straightened paper clip.

Parts required	#	Part number	Description
	1	G1313-60010	Gripper assembly

Preparations

- Select “Start” in the maintenance function “ChangeGripper”.
- Turn off the power to the autosampler.
- Remove the front cover.

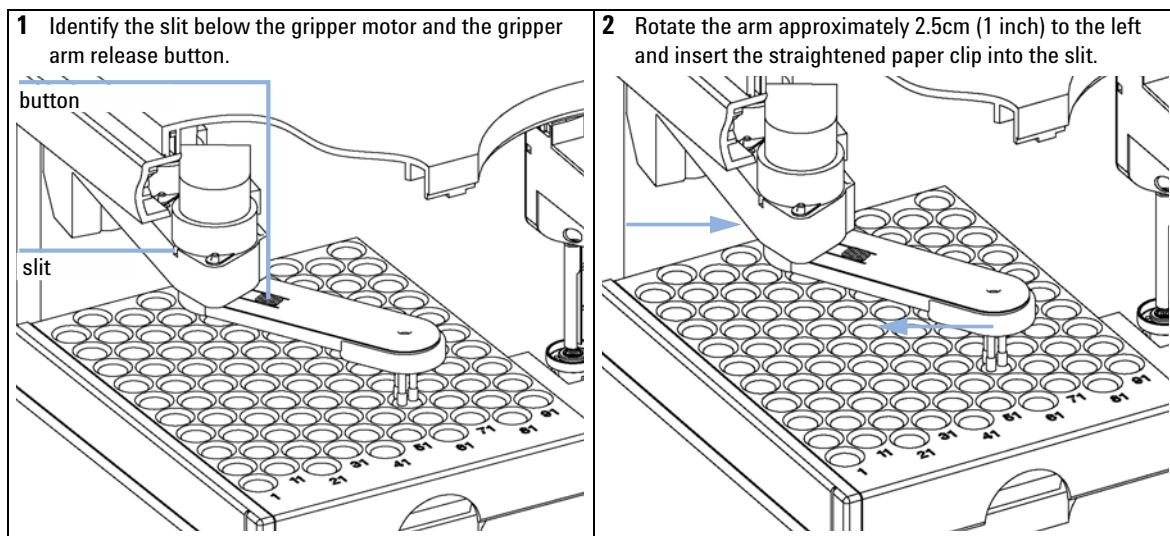

3 Rotate the gripper arm slowly from left to right and apply a gentle pressure to the paper clip. The clip will engage on an internal catch and the rotation of the arm will be blocked.

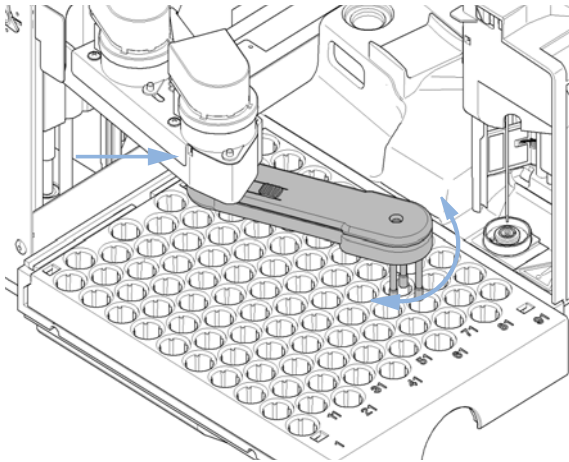

4 Hold the paper clip in place, press the gripper release button and rotate the gripper arm to the right.

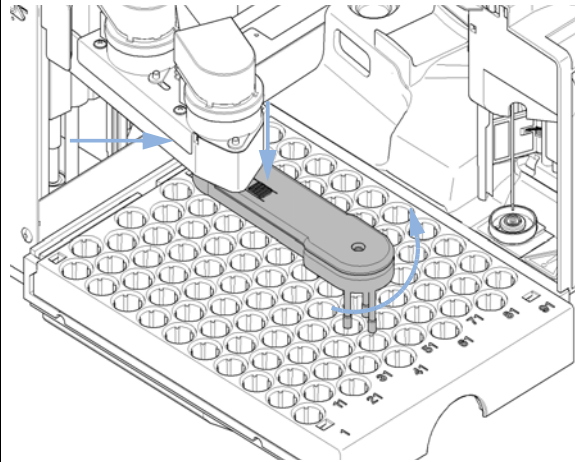

5 The gripper arm will come off.

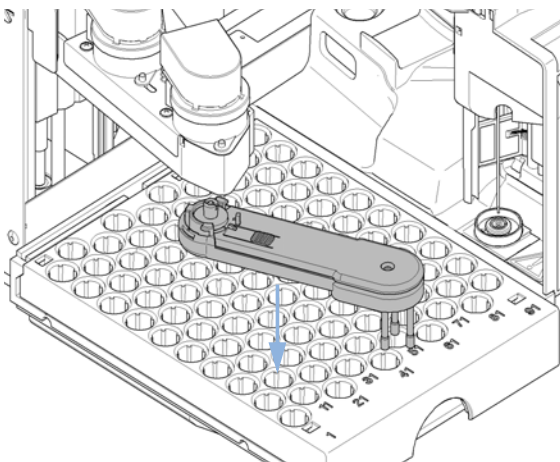

6 Replace the gripper arm by holding the paper clip in place, pushing the gripper arm into the holder and rotating the gripper arm to the left.

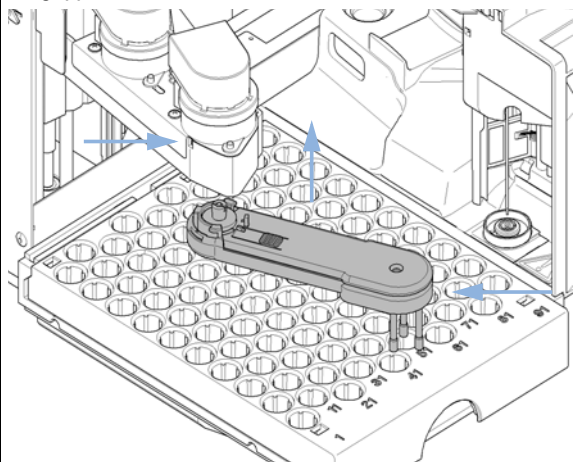

Next Steps:

- 7** On completion of this procedure: Install the front cover.
- 8** Turn the power to the autosampler ON.

Interface Board

When At installation or when defective.

Tools required • Flat-head screwdriver.

Parts required

#	Description
1	Interface board.

CAUTION

Electronic boards are static sensitive and should be handled with care so as not to damage them. Touching electronic boards and components can cause electrostatic discharge (ESD).

ESD can damage electronic boards and components.

→ Be sure to hold the board by the edges and do not touch the electrical components. Always use an ESD protection (for example, an ESD wrist strap) when handling electronic boards and components.

- 1 Switch OFF the autosampler at the main power switch.
- 2 Disconnect cables from the interface board connectors.
- 3 Loosen the screws. Slide out the interface board from the autosampler.
- 4 Install the interface board. Secure the screws.
- 5 Reconnect the cables to the board connectors

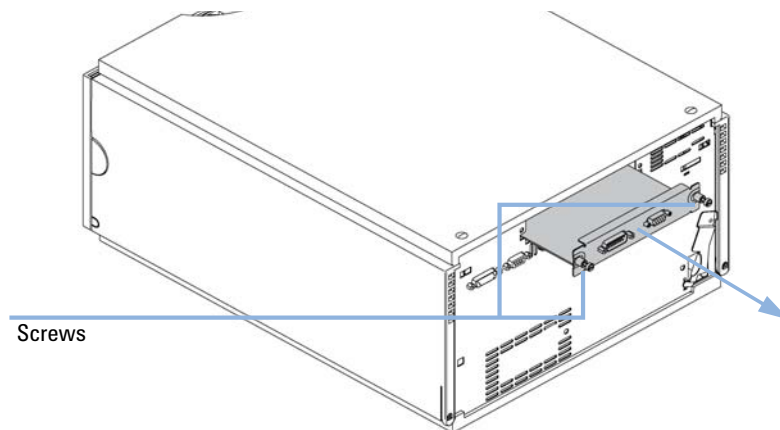

Figure 22 Exchanging the Interface Board



8 Parts and Materials for Maintenance

Main Assemblies	106
Analytical-Head Assembly	108
Vial Trays	111
Standard Autosampler Accessory Kit G1329-68725	112
Preparative Autosampler Accessory Kit G2260-68705	113
Maintenance Kit G1313-68730 for G1329A	114
Maintenance Kit G1313-68719 for G1329B	115
Multi-Draw Kit G1313-6871	116
900 µl Injection Upgrade Kit G1363A for G1329A	117
External Tray G1313-60004	118



Main Assemblies

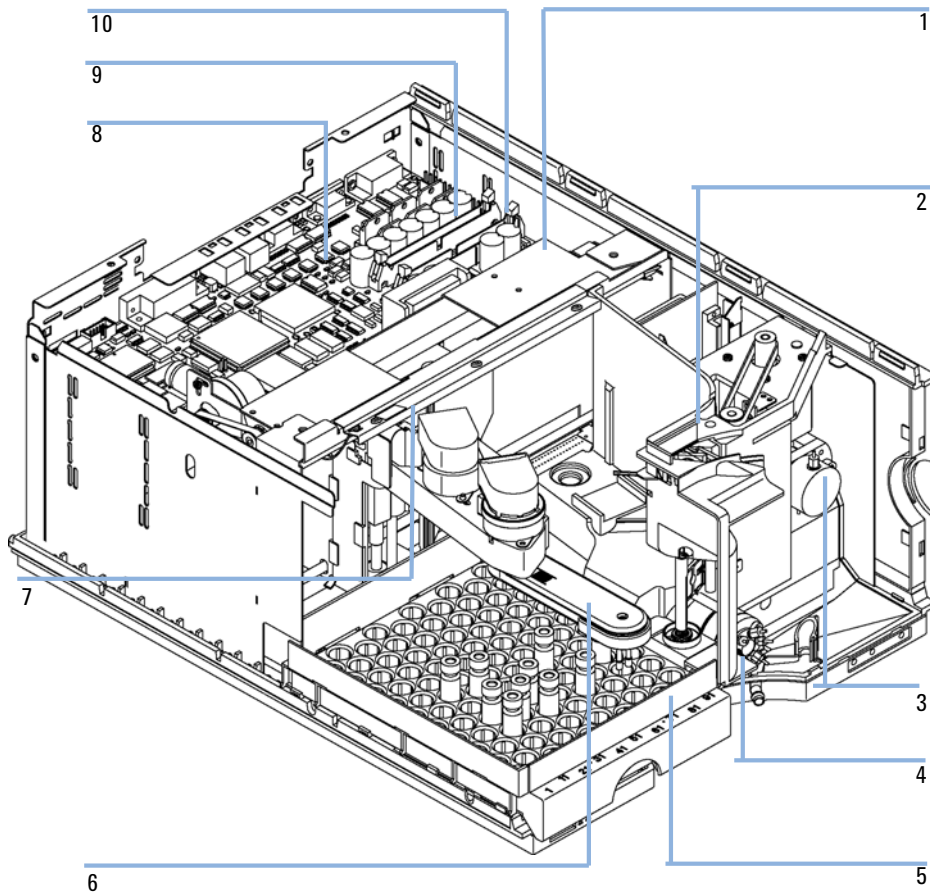

Figure 23 Autosampler Main Assemblies

Table 19 Autosampler Main Assemblies

Item	Description	Part Number
1	Transport assembly for G1329A-2260A	G1329-60009
2	Sampling unit assembly for G1329A Sampling unit assembly for G2260A (The assy comes without injection valve and analytical head)	G1329-60008 G2260-60008
3	Analytical head assembly (100 µl) for G1329A and G1329B Preparative head assembly (900 µl) for G1329A (P<200Bar) Preparative head assembly (900 µl) for G2260A (P<400Bar)	01078-60003 G1313-60007 G2260-60007
4	Injection valve assembly for G1329A Injection valve assembly for G1329B Injection valve assembly for G2260A	0101-0921 0101-1422 0101-1267
5	Vial tray, thermostatted (see “Vial Trays” on page 111)	G1329-60011
6	Gripper assembly	G1313-60010
7	Illumination assembly	G1367-60040
8	Autosampler Main Board (ASM) for G1329A and 2260A Autosampler Main Board (ASM) for G1329B	G1329-69530 G1329-66540
	Standoff - GPIB connector (part not shown)	0380-0643
	Standoff - remote connector (part not shown)	1251-7788
9	Ribbon cable, sample transport	G1313-81601
10	Ribbon cable, sampling unit	G1313-81602
	Sampler - TCC cap (380 mm 0.1 mm id) for G1329A Sampler - Column cap (600 mm, 0.5 mm id) for G2260A	01090-87306 G2260-87300
	Power supply assembly (part not shown)	0950-2528
	Screw M4, 8 mm lg - power supply (part not shown)	0515-0910
	BCD board (not shown)	G1351-68701
	Cable, autosampler to ALS thermostat (part not shown)	G1330-81600

Analytical-Head Assembly

Table 20 Analytical-Head Assembly (100 µl) for G1329A / G1329B

Item	Description	Part Number
	Analytical head assembly, includes items 1 – 6	01078-60003
1	Plunger assembly	5063-6586
2	Screw M4, 40 mm lg, for mounting of assembly	0515-0850
3	Adapter	01078-23202
4	Support seal assembly	5001-3739
5	Metering seal (pack of 2)	5063-6589
6	Head body	01078-27710
7	Screw M5, 60 mm lg, for mounting of assembly (not shown here)	0515-2118

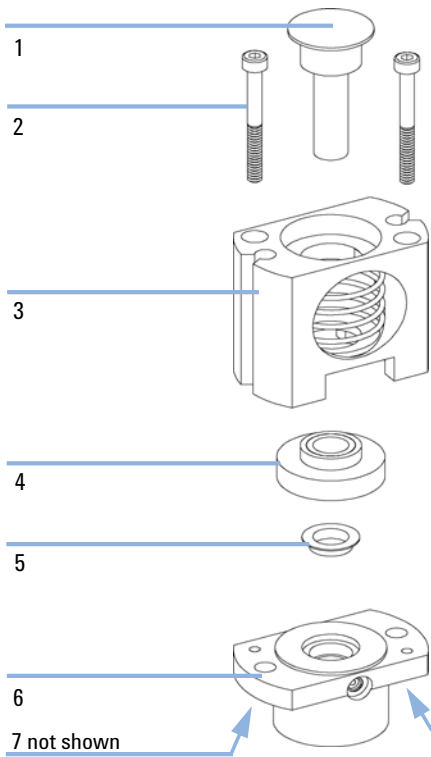

Figure 24 Analytical-Head Assembly

8 Parts and Materials for Maintenance

Analytical-Head Assembly

Table 21 Preparative-Head Assembly (900 µl) for G1329A only

Item	Description	Part Number
	Analytical head assembly 900 µl ¹ , includes items 1 – 6	G1313-60007
1	Plunger assembly, 900 µl	5062-8587
2	Screws	0515-0850
3	Adapter	01078-23202
4	Support seal assembly, 900 µl	5001-3764
5	Metering seal, 900 µl	0905-1294
6	Head body, 900 µl	G1313-27700
7	Screw M5, 60 mm lg, for mounting of assembly (not shown here)	0515-2118

¹ This head is limited to 200 Bars

Table 22 Preparative-Head Assembly (900 µl) for G2260A

Item	Description	Part Number
	Preparative head assembly 900 µl ¹ , includes items 1 – 6	G2260-60007
1	Plunger assembly, 900 µl	5062-8587
2	Screws	0515-0850
3	Adapter	01078-23202
4	Support seal assembly, 900 µl	5001-3764
5	Metering seal, 900 µl	0905-1294
6	Head body, 900 µl	G2260-27700
7	Screw M5, 60 mm lg, for mounting of assembly (not shown here)	0515-2118

¹ This head is limited to 400 Bars. It can only be assembled on a sampling unit with the description “supports 900 µl at 400 Bar.

Vial Trays

Table 23 Thermostatted Autosampler Vial Trays and Tray Base

Item	Description	Part Number
1	Adapter, air channel	G1329-43200
2	Tray for 100 × 2-ml vials, thermostattable	G1329-60011
3	Spring	G1313-09101
4	Tray base for G1329A / G1329B / G2260A (includes items 4, 5).	G1329-60000
5	Spring stud	0570-1574
	Halftray for 40 × 2-ml vials (not shown)	G1313-44512
	Halftray for 15 × 6-ml vials (not shown)	G1313-44513

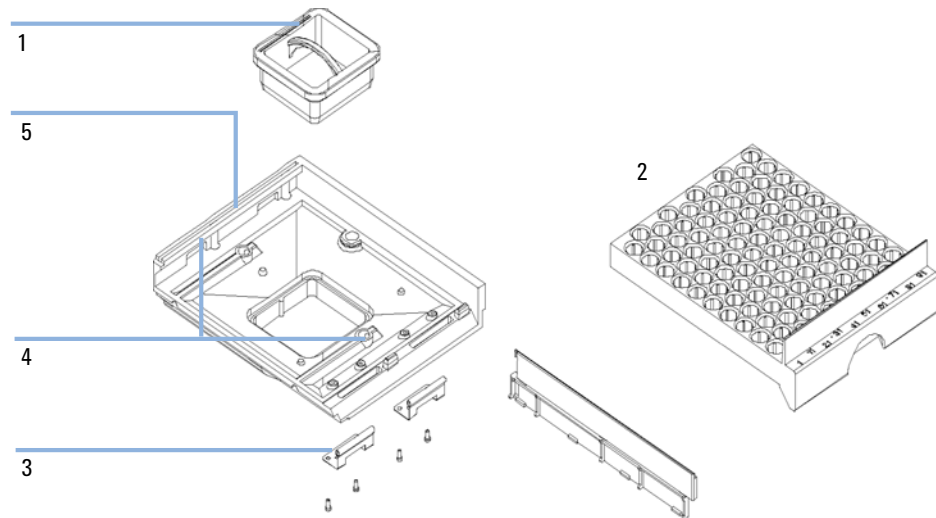

Figure 25 Thermostatted Autosampler Vial Trays and Tray Base

Standard Autosampler Accessory Kit G1329-68725

Table 24 G1329A/G1329 B - Standard Autosampler Accessory Kit Contents G1329-68725

Description	Part Number
Flexible tubing assy (120 cm)	5063-6527
Filter promo kit	no PN
CAN cable, 1 m long	5181-1519
Screw cap vials, clear 100/pk	5182-0714
Blue screw caps 100/pk	5182-0717
Label halftray	no PN
Vial instruction sheet	no PN
Wrenches 1/4 - 5/16 inch	8710-0510
Rheotool socket wrench 1/4 inch	8710-2391
Hex key 4 mm, 15 cm long, T-handle	8710-2392
Hex key 9/64 mm, 15 cm long, T- handle	8710-2394
Hex key 2.5 mm, 15 cm long, straight handle	8710-2412
Finger caps x3 (reorder gives pack of 15)	5063-6506
Front door cooled autosampler	no PN
Air channel adapter	G1329-43200
Cover insulation	no PN
Capillary 0.17 mm, 900 mm	G1329-87300
Capillary heat exchanger	01090-87306
Note for Agilent 1200 Series Autosampler door upgrade	no PN

Preparative Autosampler Accessory Kit G2260-68705

Table 25 G2260A - Preparative Autosampler Accessory Kit Contents G2260-68705

Description	Part Number
Flexible tubing assy (120 cm)	5063-6527
Filter promo kit	no PN
CAN cable, 1 m long	5181-1519
Screw cap vials, clear 100/pk	5182-0714
Blue screw caps 100/pk	5182-0717
Label halftray	no PN
Wrenches 1/4 - 5/16 inch	8710-0510
Rheotool socket wrench 1/4 inch	8710-2391
Hex key 4 mm, 15 cm long, T-handle	8710-2392
Hex key 9/64 mm, 15 cm long, T-handle	8710-2394
Hex key 2.5 mm, 15 cm long, straight handle	8710-2412
Finger caps x3 (reorder gives pack of 15)	5063-6506
Front door cooled autosampler	no PN
Air channel adapter	G1329-43200
Tray for 15 x 6 ml vials (x2)	G1313-44513
Union, loop extension	5022-2133
Seat extension capillary (500 µl)	G1313-87307
Seat extension capillary (1500 µl)	G1313-87308
Sampler - Column capillary	G2260-87300
Pump - Sampler capillary	G2260-87301

Maintenance Kit G1313-68730 for G1329A

Table 26 Maintenance Kit for G1329A

Item	Description	Part Number
1	Rotor seal (Vespel)	0100-1853
2	Needle assembly (100 µl)	G1313-87201
3	Needle-seat assembly 0.17 mm, 2.3 µl	G1313-87101

Maintenance Kit G1313-68719 for G1329B

Table 27 Maintenance Kit for G1329A

Item	Description	Part Number
1	Rotor seal (PEEK)	0101-1416
2	Needle assembly (100 µl)	G1313-87201
3	Needle-seat assembly 0.17 mm	G1313-87101
4	Metering seal (pack of 2)	5063-6589
5	Finger caps (pack of 15)	5063-6506

Multi-Draw Kit G1313-6871

Table 28 Multi-Draw Kit for G1329A and G1329B

Item	Description	Part Number
1	Seat capillary, 500 µl, 0.5 mm id	G1313-87307
2	Seat capillary, 1500 µl, 0.9 mm id	G1313-87308
2	Seat capillary, 5000 µl	0101-0301
3	Union	5022-6515

900 µl Injection Upgrade Kit G1363A for G1329A

Table 29 900 µl Injection Upgrade Kit for G1329A only

Item	Description	Part Number
1	Analytical Head, 900 µl	G1313-60007
2	Loop Extension, 900 µl	G1313-87303
3	Union, loop extension	5022-2133
4	Needle, 900 µl	G1313-87202

External Tray G1313-60004

Table 30 External Tray

Item	Description	Part Number
1	External tray	G1313-60004
2	Disposal tube	G1313-27302



9 Identifying Cables

Cable Overview	120
Analog Cables	122
Remote Cables	125
BCD Cables	130
External Contact Cable	132
CAN/LAN Cables	133
Auxiliary Cable	134
RS-232 Cables	135



Cable Overview

NOTE

Never use cables other than the ones supplied by Agilent Technologies to ensure proper functionality and compliance with safety or EMC regulations.

Type	Description	Part Number
Analog cables	3390/2/3 integrators	01040-60101
	3394/6 integrators	35900-60750
	Agilent 35900A A/D converter	35900-60750
	General purpose (spade lugs)	01046-60105
Remote cables	3390 integrator	01046-60203
	3392/3 integrators	01046-60206
	3394 integrator	01046-60210
	3396A (Series I) integrator	03394-60600
	3396 Series II / 3395A integrator, see details in section "Remote Cables" on page 125	
	3396 Series III / 3395B integrator	03396-61010
	HP 1050 modules / HP 1046A FLD	5061-3378
	HP 1046A FLD	5061-3378
	Agilent 35900A A/D converter	5061-3378
	HP 1040 diode-array detector	01046-60202
	HP 1090 liquid chromatographs	01046-60202
	Signal distribution module	01046-60202
	<i>BCD cables</i>	3396 integrator
General purpose (spade Lugs)		G1351-81600
<i>Auxiliary</i>	Agilent 1100 Series vacuum degasser	G1322-61600

Type	Description	Part Number
<i>CAN cables</i>	Agilent 1100/1200 module to module, 0.5m lg	5181-1516
	Agilent 1100/1200 module to module, 1m lg	5181-1519
<i>External contacts</i>	Agilent 1100/1200 Series interface board to general purpose	G1103-61611
<i>GPIB cable</i>	Agilent 1100/1200 module to ChemStation, 1 m	10833A
	Agilent 1100/1200 module to ChemStation, 2 m	10833B
<i>RS-232 cable</i>	Agilent 1100/1200 module to a computer This kit contains a 9-pin female to 9-pin female Null Modem (printer) cable and one adapter.	34398A
<i>LAN cable</i>	Twisted pair cross over LAN cable, (shielded 3m long) (for point to point connection)	5023-0203
	Twisted pair cross over LAN cable, (shielded 7m long) (for point to point connection)	5023-0202

Analog Cables

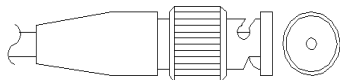

One end of these cables provides a BNC connector to be connected to Agilent 1100/1200 Series modules. The other end depends on the instrument to which connection is being made.

Agilent 1100/1200 to 3390/2/3 Integrators

Connector 01040-60101	Pin 3390/2/3	Pin Agilent 1100/1200	Signal Name
	1	Shield	Ground
	2		Not connected
	3	Center	Signal +
	4		Connected to pin 6
	5	Shield	Analog -
	6		Connected to pin 4
	7		Key
	8		Not connected

Agilent 1100/1200 to 3394/6 Integrators

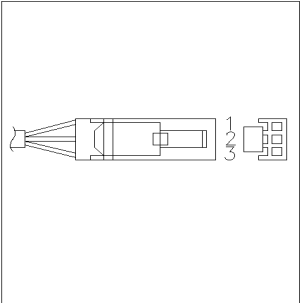
Connector 35900-60750	Pin 3394/6	Pin Agilent 1100/1200	Signal Name
	1		Not connected
	2	Shield	Analog -
	3	Center	Analog +

Agilent 1100/1200 to BNC Connector

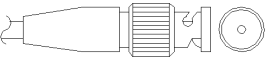
Connector 8120-1840	Pin BNC	Pin Agilent 1100/1200	Signal Name
	Shield	Shield	Analog -
	Center	Center	Analog +

9 Identifying Cables
Analog Cables

Agilent 1100/1200 to General Purpose

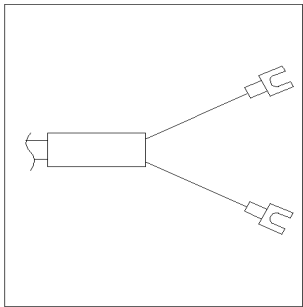
Connector 01046-60105	Pin 3394/6	Pin Agilent 1100/1200	Signal Name
	1		Not connected
	2	Black	Analog -
	3	Red	Analog +

Remote Cables



One end of these cables provides a Agilent Technologies APG (Analytical Products Group) remote connector to be connected to Agilent 1100/1200 Series modules. The other end depends on the instrument to be connected to.

Agilent 1100/1200 to 3390 Integrators

Connector 01046-60203	Pin 3390	Pin Agilent 1100/1200	Signal Name	Active (TTL)
<p>A diagram of the 9-pin connector from the Agilent 1100/1200 side. The pins are arranged in a circular pattern, numbered 1 through 9. Pin 1 is at the top, pin 2 is to the left, pin 3 is to the right, pin 4 is at the bottom, pin 5 is to the left, pin 6 is to the right, pin 7 is at the top, pin 8 is to the left, and pin 9 is to the right.</p>	2	1 - White	Digital ground	
	NC	2 - Brown	Prepare run	Low
	7	3 - Gray	Start	Low
	NC	4 - Blue	Shut down	Low
	NC	5 - Pink	Not connected	
	NC	6 - Yellow	Power on	High
	NC	7 - Red	Ready	High
	NC	8 - Green	Stop	Low
	NC	9 - Black	Start request	Low

Agilent 1100/1200 to 3392/3 Integrators

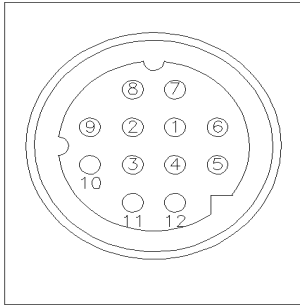
Connector 01046-60206	Pin 3392/3	Pin Agilent 1100/1200	Signal Name	Active (TTL)
	3	1 - White	Digital ground	
	NC	2 - Brown	Prepare run	Low
	11	3 - Gray	Start	Low
	NC	4 - Blue	Shut down	Low
	NC	5 - Pink	Not connected	
	NC	6 - Yellow	Power on	High
	9	7 - Red	Ready	High
	1	8 - Green	Stop	Low
	NC	9 - Black	Start request	Low

Agilent 1100/1200 to 3394 Integrators

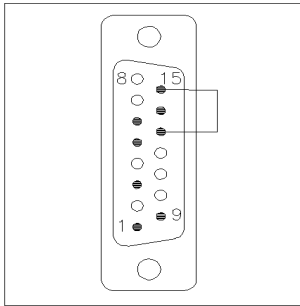
Connector 01046-60210	Pin 3394	Pin Agilent 1100/1200	Signal Name	Active (TTL)
	9	1 - White	Digital ground	
	NC	2 - Brown	Prepare run	Low
	3	3 - Gray	Start	Low
	NC	4 - Blue	Shut down	Low
	NC	5 - Pink	Not connected	
	NC	6 - Yellow	Power on	High
	5,14	7 - Red	Ready	High
	6	8 - Green	Stop	Low
	1	9 - Black	Start request	Low
	13, 15		Not connected	

NOTE

START and STOP are connected via diodes to pin 3 of the 3394 connector.

Agilent 1100/1200 to 3396A Integrators

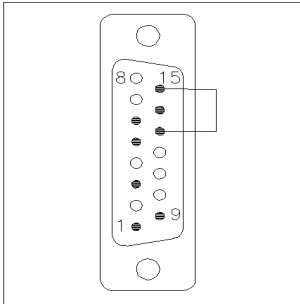
Connector 03394-60600	Pin 3394	Pin Agilent 1100/1200	Signal Name	Active (TTL)
	9	1 - White	Digital ground	
	NC	2 - Brown	Prepare run	Low
	3	3 - Gray	Start	Low
	NC	4 - Blue	Shut down	Low
	NC	5 - Pink	Not connected	
	NC	6 - Yellow	Power on	High
	5,14	7 - Red	Ready	High
	1	8 - Green	Stop	Low
	NC	9 - Black	Start request	Low
	13, 15		Not connected	

Agilent 1100/1200 to 3396 Series II / 3395A Integrators

Use the cable **part number: 03394-60600** and cut pin #5 on the integrator side. Otherwise the integrator prints START; not ready.

Agilent 1100/1200 to 3396 Series III / 3395B Integrators

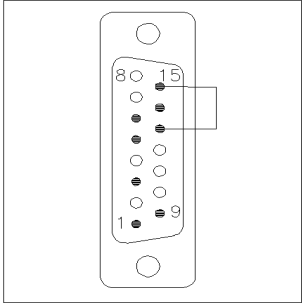
Connector 03396-61010	Pin 33XX	Pin Agilent 1100/1200	Signal Name	Active (TTL)
	9	1 - White	Digital ground	
	NC	2 - Brown	Prepare run	Low
	3	3 - Gray	Start	Low
	NC	4 - Blue	Shut down	Low
	NC	5 - Pink	Not connected	
	NC	6 - Yellow	Power on	High
	14	7 - Red	Ready	High
	4	8 - Green	Stop	Low
	NC	9 - Black	Start request	Low
	13, 15		Not connected	

Agilent 1100/1200 to HP 1050, HP 1046A or Agilent 35900 A/D Converters

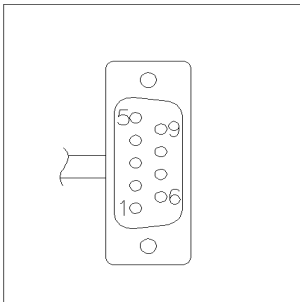
Connector 5061-3378	Pin HP 1050/....	Pin Agilent 1100/1200	Signal Name	Active (TTL)
	1 - White	1 - White	Digital ground	
	2 - Brown	2 - Brown	Prepare run	Low
	3 - Gray	3 - Gray	Start	Low
	4 - Blue	4 - Blue	Shut down	Low
	5 - Pink	5 - Pink	Not connected	
	6 - Yellow	6 - Yellow	Power on	High
	7 - Red	7 - Red	Ready	High
	8 - Green	8 - Green	Stop	Low
	9 - Black	9 - Black	Start request	Low

Agilent 1100/1200 to HP 1090 LC or Signal Distribution Module

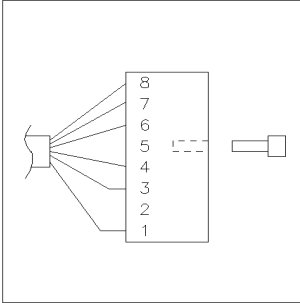
Connector01046-60202	Pin HP 1090	Pin Agilent 1100/1200	Signal Name	Active (TTL)
	1	1 - White	Digital ground	
	NC	2 - Brown	Prepare run	Low
	4	3 - Gray	Start	Low
	7	4 - Blue	Shut down	Low
	8	5 - Pink	Not connected	
	NC	6 - Yellow	Power on	High
	3	7 - Red	Ready	High
	6	8 - Green	Stop	Low
	NC	9 - Black	Start request	Low

Agilent 1100/1200 to General Purpose

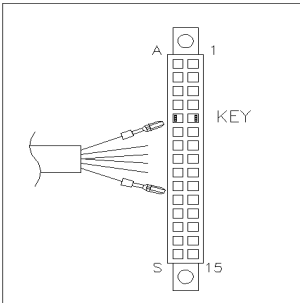
Connector01046-60201	Pin Universal	Pin Agilent 1100/1200	Signal Name	Active (TTL)
		1 - White	Digital ground	
		2 - Brown	Prepare run	Low
		3 - Gray	Start	Low
		4 - Blue	Shut down	Low
		5 - Pink	Not connected	
		6 - Yellow	Power on	High
		7 - Red	Ready	High
		8 - Green	Stop	Low
		9 - Black	Start request	Low

BCD Cables



One end of these cables provides a 15-pin BCD connector to be connected to the Agilent 1200 Series modules. The other end depends on the instrument to be connected to

Agilent 1200 to General Purpose

Connector G1351-81600	Wire Color	Pin Agilent 1200	Signal Name	BCD Digit
	Green	1	BCD 5	20
	Violet	2	BCD 7	80
	Blue	3	BCD 6	40
	Yellow	4	BCD 4	10
	Black	5	BCD 0	1
	Orange	6	BCD 3	8
	Red	7	BCD 2	4
	Brown	8	BCD 1	2
	Gray	9	Digital ground	Gray
	Gray/pink	10	BCD 11	800
	Red/blue	11	BCD 10	400
	White/green	12	BCD 9	200
	Brown/green	13	BCD 8	100
	not connected	14		
	not connected	15	+ 5 V	Low

Agilent 1200 to 3396 Integrators

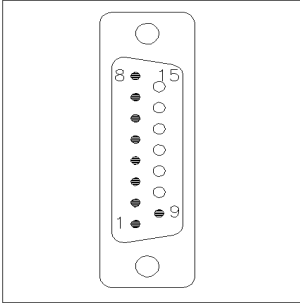
Connector 03396-60560	Pin 3392/3	Pin Agilent 1200	Signal Name	BCD Digit
	1	1	BCD 5	20
	2	2	BCD 7	80
	3	3	BCD 6	40
	4	4	BCD 4	10
	5	5	BCD0	1
	6	6	BCD 3	8
	7	7	BCD 2	4
	8	8	BCD 1	2
	9	9	Digital ground	
	NC	15	+ 5 V	Low

External Contact Cable

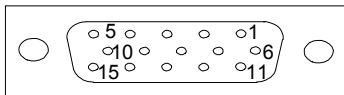

One end of this cable provides a 15-pin plug to be connected to Agilent 1200 Series module's interface board. The other end is for general purpose.

Agilent 1200 Series Interface Board to general purposes

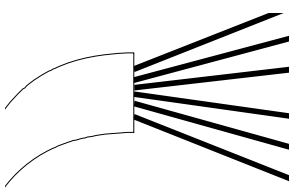
Connector G1103-61611	Color	Pin Agilent 1200	Signal Name
	White	1	EXT 1
	Brown	2	EXT 1
	Green	3	EXT 2
	Yellow	4	EXT 2
	Grey	5	EXT 3
	Pink	6	EXT 3
	Blue	7	EXT 4
	Red	8	EXT 4
	Black	9	Not connected
	Violet	10	Not connected
	Grey/pink	11	Not connected
	Red/blue	12	Not connected
	White/green	13	Not connected
	Brown/green	14	Not connected
	White/yellow	15	Not connected

CAN/LAN Cables

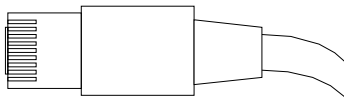

Both ends of this cable provide a modular plug to be connected to Agilent 1200 Series module's CAN or LAN connectors.

CAN Cables

Agilent 1200 module to module, 0.5 m	5181-1516
Agilent 1200 module to module, 1 m	5181-1519
Agilent 1200 module to control module	G1323-81600

LAN Cables

Description	Part number
Cross-over network cable (shielded, 3 m long), (for point to point connection)	5023-0203
Twisted pair network cable (shielded, 7 m long) (for hub connections)	5023-0202

Auxiliary Cable

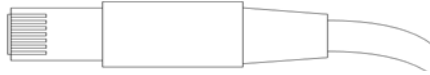

One end of this cable provides a modular plug to be connected to the Agilent 1100 Series vacuum degasser. The other end is for general purpose.

Agilent 1100 Series Degasser to general purposes

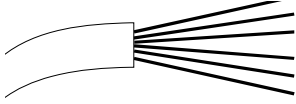
Connector G1322-81600	Color	Pin Agilent 1100	Signal Name
	White	1	Ground
	Brown	2	Pressure signal
	Green	3	
	Yellow	4	
	Grey	5	DC + 5 V IN
	Pink	6	Vent

RS-232 Cables

Description	Part number
RS-232 cable, instrument to PC, 9-to-9 pin (female) This cable has special pin-out, and is not compatible with connecting printers and plotters.	24542U G1530-60600
RS-232 cable kit, 9-to-9 pin (female) and one adapter 9-pin (male) 25-pin female. Suited for instrument to PC.	34398A
Cable Printer Serial & Parallel, is a SUB-D 9 pin female vs. Centronics connector on the other end (NOT FOR FW UPDATE).	5181-1529
This kit contains a 9-pin female to 9-pin female Null Modem (printer) cable and one adapter. Use the cable and adapter to connect Agilent Technologies instruments with 9-pin male RS-232 connectors to most PCs or printers.	34398A

9 Identifying Cables

RS-232 Cables



10 Appendix

General Safety Information	138
Lithium Batteries Information	142
Radio Interference	143
Sound Emission	144
Agilent Technologies on Internet	145



General Safety Information

General Safety Information

The following general safety precautions must be observed during all phases of operation, service, and repair of this instrument. Failure to comply with these precautions or with specific warnings elsewhere in this manual violates safety standards of design, manufacture, and intended use of the instrument. Agilent Technologies assumes no liability for the customer's failure to comply with these requirements.

WARNING

Ensure the proper usage of the equipment.

The protection provided by the equipment may be impaired.

→ The operator of this instrument is advised to use the equipment in a manner as specified in this manual.

General

This is a Safety Class I instrument (provided with terminal for protective earthing) and has been manufactured and tested according to international safety standards.

Operation

Before applying power, comply with the installation section. Additionally the following must be observed.

Do not remove instrument covers when operating. Before the instrument is switched on, all protective earth terminals, extension cords, auto-transformers, and devices connected to it must be connected to a protective earth via a ground socket. Any interruption of the protective earth grounding will cause a potential shock hazard that could result in serious personal injury. Whenever it is likely that the protection has been impaired, the instrument must be made inoperative and be secured against any intended operation.

Make sure that only fuses with the required rated current and of the specified type (normal blow, time delay, and so on) are used for replacement. The use of repaired fuses and the short-circuiting of fuse holders must be avoided.

Some adjustments described in the manual, are made with power supplied to the instrument, and protective covers removed. Energy available at many points may, if contacted, result in personal injury.

Any adjustment, maintenance, and repair of the opened instrument under voltage should be avoided whenever possible. When inevitable, this has to be carried out by a skilled person who is aware of the hazard involved. Do not attempt internal service or adjustment unless another person, capable of rendering first aid and resuscitation, is present. Do not replace components with power cable connected.

Do not operate the instrument in the presence of flammable gases or fumes. Operation of any electrical instrument in such an environment constitutes a definite safety hazard.

Do not install substitute parts or make any unauthorized modification to the instrument.

Capacitors inside the instrument may still be charged, even though the instrument has been disconnected from its source of supply. Dangerous voltages, capable of causing serious personal injury, are present in this instrument. Use extreme caution when handling, testing and adjusting.





10 Appendix

General Safety Information

When working with solvents please observe appropriate safety procedures (e.g. goggles, safety gloves and protective clothing) as described in the material handling and safety data sheet by the solvent vendor, especially when toxic or hazardous solvents are used.

Safety Symbols

Table 31 Safety Symbols

Symbol	Description
	The apparatus is marked with this symbol when the user should refer to the instruction manual in order to protect risk of harm to the operator and to protect the apparatus against damage.
	Indicates dangerous voltages.
	Indicates a protected ground terminal.
	Indicates eye damage may result from directly viewing the light produced by the deuterium lamp used in this product.
	The apparatus is marked with this symbol when hot surfaces are available and the user should not touch it when heated up.

WARNING

A WARNING

alerts you to situations that could cause physical injury or death.

- Do not proceed beyond a warning until you have fully understood and met the indicated conditions.

CAUTION

A CAUTION

alerts you to situations that could cause loss of data, or damage of equipment.

- Do not proceed beyond a caution until you have fully understood and met the indicated conditions.

Lithium Batteries Information

WARNING

Lithium batteries may not be disposed-off into the domestic waste. Transportation of discharged Lithium batteries through carriers regulated by IATA/ICAO, ADR, RID, IMDG is not allowed.

Danger of explosion if battery is incorrectly replaced.

- Discharged Lithium batteries shall be disposed off locally according to national waste disposal regulations for batteries.
- Replace only with the same or equivalent type recommended by the equipment manufacturer.



WARNING

Lithiumbatteri - Eksplosionsfare ved fejlagtig håndtering.

Udskiftning må kun ske med batteri af samme fabrikat og type.

- Lever det brugte batteri tilbage til leverandøren.

WARNING

Lithiumbatteri - Eksplosionsfare.

Ved udskiftning benyttes kun batteri som anbefalt av apparatfabrikanten.

- Brukt batteri returneres apparatleverandøren.

NOTE

Bij dit apparaat zijn batterijen geleverd. Wanneer deze leeg zijn, moet u ze niet weggooien maar inleveren als KCA.

Radio Interference

Cables supplied by Agilent Technologies are screened to provide optimized protection against radio interference. All cables are in compliance with safety or EMC regulations.

Test and Measurement

If test and measurement equipment is operated with unscreened cables, or used for measurements on open set-ups, the user has to assure that under operating conditions the radio interference limits are still met within the premises.

Sound Emission

Manufacturer's Declaration

This statement is provided to comply with the requirements of the German Sound Emission Directive of 18 January 1991.

This product has a sound pressure emission (at the operator position) < 70 dB.

- Sound Pressure $L_p < 70$ dB (A)
- At Operator Position
- Normal Operation
- According to ISO 7779:1988/EN 27779/1991 (Type Test)

Agilent Technologies on Internet

For the latest information on products and services visit our worldwide web site on the Internet at:

<http://www.agilent.com>

Select Products/Chemical Analysis

It will provide also the latest firmware of the Agilent 1200 Series modules for download.

Index

A

Agilent
 on internet 145
 air circulation 26
 algae information 54
 ambient operating temperature 27
 ambient non-operating temperature 27
 analog
 cable 120, 122
 analytical head 14
 autosampler accessory kit contents 112, 113
 auxiliary
 cable 120, 134

B

battery
 safety information 142
 BCD
 cable 120, 130
 bench space 26, 26
 bypass 11
 bypassing the autosampler 58

C

cable
 analog 120, 122
 auxiliary 120, 134
 BCD 120, 130
 CAN 133
 connecting APG remote 38, 40
 connecting the ChemStation 38, 40
 connecting the power 38, 40
 connecting CAN 38, 40

connecting GPIB 38, 40
 connecting LAN 38, 40
 external contact 132
 external contacts 121
 GPIB 121
 LAN 121, 133
 remote 120, 125
 RS-232 121, 135
 cables
 overview 120
 CAN
 cable 133
 capillaries 48
 choice of vials and caps 68
 cleaning 79
 condensation 26

D

damaged packaging 34, 34
 delay volume 51, 58, 58
 delay 51
 delivery checklist 34, 34
 dimensions 27
 draw speed 68, 68
 DRAW 68

E

eject speed 68, 68
 EJECT 68
 electrical connections
 descriptions of 19
 electrostatic discharge (ESD) 104
 environment 24, 26
 error messages 73

ESD (electrostatic discharge) strap 78, 78
 external contact
 cable 121, 132

F

failure 73
 flow connections 48
 frequency range 27
 fuses 24

G

GPIB
 cable 121
 gripper fingers 16
 gripper
 alignment 73
 external vials 73

H

half trays 56
 humidity 27

I

information
 on sound emission 144
 injection valve 8, 13
 injection volume precision 68
 injection volumes less than 2 μ l 68
 injection volumes 68
 injection sequence 11
 injection valve 15
 installation

Index

- power cords 25
- installing the autosampler
 - sample trays 56
- installing the sample tray 50
- installing the thermostatted autosampler
 - power cable and interface cable 46
 - preparation 45
- installing the thermostatted autosampler
 - interface cables 44
 - power cable 44
 - safety 41, 44
 - tray cover and front cover 58
- installing the tray cover front door 58
- installing the autosampler
 - flow connections 48
 - interface cables 41
 - safety 41
- installing the autosampler 41
 - power cable 41
- internet 145
- introduction to the autosampler 8

L

- LAN
 - cable 121, 133
- line frequency 27
- line voltage 27
- lithium batteries 142
- low volume injections 68
- low-volume capillary kit 58

M

- mainpass 11
- maintenance functions 73, 84
- metering device 13, 68
- metering seal 900 µl 110, 110
- metering seal 108
- missing parts 34
- multi-draw option 8

N

- needle drive 13, 14
- non-operating altitude 27
- non-operating temperature 27
- numbering of vials 56

O

- operating Altitude 27
- operating temperature 27
- optimizing performance
 - automated needle wash 68
 - delay volume 68
 - delay-volume adjustment 68
 - inject-valve seal 68
 - low-volume capillary kit 68
 - maintenance 68
- optimizing performance
 - bypassing the autosampler 58
 - low-volume capillary kit 58
 - minimizing delay volume 51, 58, 58

P

- park transport assembly 34
- park transport assembly 58
- parts and materials
 - 900 µl injection upgrade kit 117
 - accessory kit 112
 - external tray 118
 - main assemblies 106
 - maintenance kit 114
 - multi-draw kit 116
 - preparative ALS acc. kit 113
 - standard autosampler accessory kit 112
 - vial trays and tray base 111
- parts and materials
 - analytical-head assembly (optional 900 microlitre) 108
 - analytical-head assembly 108

- autosampler main assemblies 107
 - preparative-head assembly 110
- performance specifications
 - autosampler 28, 29, 30
 - preparative autosampler 31
- physical specifications 34
- physical specifications 27
- Power Consideration 24
- power consumption 27
- power cords 25
- power requirements 24
- preparative autosampler accessory kit contents 36
- preparative head 14

R

- radio interference 143
- remote
 - cable 120, 125
- repair procedures 80
- repairs
 - metering plunger 98
 - metering seal 98
 - needle assembly 86
 - needle-seat assembly 89
 - rotor seal 94
 - simple repairs 85
 - stator face 91
 - using the ESD strap 78, 78
- RS-232
 - cable 121
- RS-232C
 - cable 135

S

- safety class I 138
- safety information
 - lithium batteries 142
- safety

Index

- general information 138, 138
- standards 27
- symbols 141
- sample trays 56
 - numbering of vial positions 57
- sampling unit 13
- sampling sequence 10
- seals
 - metering seal 108, 110, 110
- shipping 34, 58
- simple repairs 85
- site requirements 24
- sound emission 144
- specification
 - physical 27
- specifications 28, 34
- stack configuration 38, 40
 - rear view 38, 40
- standard autosampler accessory kit
 - contents 35
- stator 15
- status indicator 73
- step functions 73
- stepper motor 14

T

- temperature 28
- theta-axis 16
- transport assembly 16
- transport mechanism 8
- transport 58

U

- unpacking the autosampler 34, 34

V

- valve capillaries 48
- vial contents temperature 28

- vial numbering 56
- vial racks 8
- vial tray 58
- vials 8
- viscous samples 68, 68
- voltage range 27
- volume 51

W

- weight 26, 27

X

- X-axis 16

Z

- Z-axis 16

In This Book

This manual contains user information about the Agilent 1200 Series Standard and Preparative Autosamplers.

The manual describes the following:

- introduction to the autosampler,
- site requirements and specifications
- installing the autosampler,
- using the autosampler,
- optimizing performance,
- troubleshooting and diagnostics,
- maintenance,
- parts and materials,
- cable overview,
- safety and warranty.

© Agilent Technologies 2006,2008

Printed in Germany
11/08



G1329-90012



Agilent Technologies